



# QA-TEMP



Visit the QA-TEMP page for news, updates and downloads



## CONTENTS

Product overview	3
Inputs	4
Outputs	4
Communication interface	4
Reports and alerts	4
Data logging	4
Technical Specifications	5
Electrical characteristics	5
Communication characteristics	5
General data	6
Order codes	6
Connection and installation	7
RS485 bus termination	8
Status LEDs	9
Data logging - data acquisition	9
Product features	10
Modbus	10

Inputs/outputs	10
Analogue output alarm	11
Digital output alarm	11
Device configuration	12
Dip-switch Modbus RTU address and baud rate setting	12
Functionality configuration	12
Q-WIZARD	12
Third-party Modbus Master	13
Function 03 Hexadecimal (Read Holding Registers)	13
Function 06 Hexadecimal (Write Single Holding Register)	14
Function 10 Hexadecimal (Write Multiple Registers)	15
Firmware update	15
Register map	16



## SAFETY WARNINGS AND CAUTIONS

The following warnings and cautions must be observed to ensure personal safety and prevent damage.



**Death** or **serious injury** may result from failure to heed this warning.



It is necessary to comply with national regulations when installing and picking materials for power lines.



**Material damage** or **serious personal injury** may result from failure to heed this warning.



Repairs and modifications must be carried out only by the manufacturer. It is forbidden to open the case and make any changes to the device. Tampering with the device will invalidate the warranty.



The manufacturer **declines all responsibility** for electrical safety in the event of improper use of the equipment.



It is essential to read the entire contents of this manual before carrying out any work.



The product described in this document may only be used for the specified application. The maximum performance data and environmental conditions specified in the product data sheet must be observed. Proper transport and storage, as well as professional assembly, installation, handling and maintenance are required for the correct and safe operation of the device.



Before commissioning, make sure that:

- the maximum values for all connections are not exceeded; refer to the product data sheet;
- the connection cables are not damaged or live during wiring;
- the direction of current flow and phase rotation are correct.

During installation, ensure that a switch or circuit-breaker is near the product and easily accessible.

The unit must be uninstalled if safe operation can no longer be guaranteed (e.g. visible damage). Disconnect all connections in this case. The unit should be returned to the manufacturer or to an authorised service centre for repair.

Use under ambient conditions other than those specified, application of signals or voltages other than those specified, may cause significant deviations from the specified measurement tolerances, which may be irreversible.



**WARNING:** High-intensity magnetic fields may alter the values measured by the transformer. Avoid installation near: permanent magnets, electromagnets, or iron masses. If irregularities are detected, reposition or move the unit to a more suitable location.



Although the contents of this document have been checked for accuracy, it may contain errors or inconsistencies and we cannot guarantee its completeness or accuracy.



This document is subject to periodic revision and updating. QEED reserves the right to make changes to the product and/or its technical documentation at any time in the interests of continuous quality improvement. Always consult the latest version of the documentation available on the website:

[www.qeed.it](http://www.qeed.it)

If you find any errors or missing information in this document, please notify us by e-mail to:

[technical@qeed.it](mailto:technical@qeed.it)



Failure to observe the warnings may result in damage to the equipment or failure to operate as intended.



Disposal of waste electrical and electronic equipment (applicable in the European Union and other countries with separate collection). The symbol on the product or its packaging indicates that the product should not be treated as household waste. Instead, it will be handed over to an authorised collection point for the recycling of electrical and electronic waste. Ensuring that the product is disposed of properly will prevent potential negative effects on the environment and human health, which could otherwise be caused by inappropriate waste management of the product. Recycling materials helps to conserve natural resources. For further information, please contact your local authority, waste disposal service or the retailer from whom you purchased the product.



Please note that the information on the nameplate must be observed.





## PRODUCT OVERVIEW

The QA-TEMP is a universal temperature isolator/converter, configurable via USB and RS485, able to read analogue inputs in resistance and temperature (PT100, PT500, PT1000, Ni100m, thermocouples type: J, K, R, S, T, B, E, N) with automatic sensor break detection.

It has a software configurable 0...20mA or 0...10V output and an alarm contact. It can run from both AC or DC power.

It has full galvanic isolation between power supply, serial and USB interface and inputs and outputs.

Power/error/communication/output status LEDs are on the front of the case.

RS485 serial interface for communication with Modbus RTU protocol, either from the **Q-WIZARD configuration tool (download at link)**, or with third party Modbus masters by acting on register map registers.

Data acquisition via USB with integrated real-time clock data storage, with cable or OTG pendrive only.

Ready for DIN rail mounting with T-BUS terminal (optional) for fast connection with hot insertion/removal option.

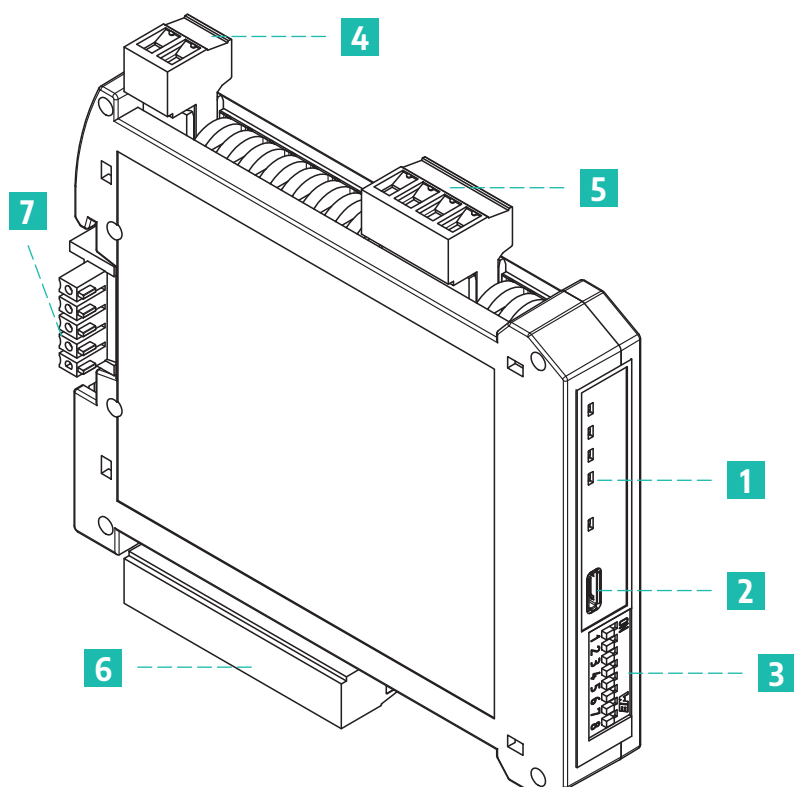

- 1 Status LEDs
- 2 MicroUSB Port
- 3 Settings DIP switch
- 4 Power supply terminals
- 5 Input terminals
- 6 Output terminals
- 7 T-BUS terminal for both power supply and Modbus RTU communication (optional)



## Inputs

- **Temperature:**
  - RTD: Pt100, Pt500, Pt1000, Ni100 (type 385). 2,3 or 4-wire measurement, automatic wire break detection, up to 400Ω or 4000Ω
  - Thermocouple: J, K, R, S, T, B, E, N; automatic thermocouple break detection (with over-range flag)
- **Potentiometer:** 1000Ω to 10kΩ
- **Resistance:** 400Ω or 4kΩ measurement. 2,3 or 4-wire measurement

## Outputs

- **Voltage:** configurable\* 0-10V, minimum load resistance 2kΩ
- **Current:** configurable\* 0...20mA, maximum load resistance 600Ω
- **Alarm contact** 5A / 230V<sub>AC</sub> relay, configurable via **Q-WIZARD software**

## Communication interface

- **RS485 Modbus RTU:** connection to RS485 serial bus on module base via adapter (T-BUS optional) or terminals. Front dip-switch for manual setting of address and baud rate
- **USB** for configuration

\* Using the configuration software, it is possible to scale the inputs and outputs as required, selecting the input measurement interval (**low limit input range** and **high limit input range** parameters in the configuration software) to which the analogue output signal is assigned (**low limit output range** and **high limit output range** parameters in the configuration software).

If manual control via Modbus RTU is selected from the interface, it is possible to manage the module as if it were an AO (Analogue Output) or a DO (Digital Output), thus freeing the analogue and digital output from the selected input. The analogue output is managed via the RS485 Modbus RTU (see register map).

## Reports and alerts

The device notifies the user of the following faults via the LED interface:

- Input signal below threshold
- Input signal above threshold
- HW error in the measurement chain
- LOG problem of the real time clock storing the date and time
- RTC problem during data acquisition (no memory on USB stick, USB stick not recognised)
- EEPROM problem on the configuration microprocessor (module out of order, configuration lost)

These anomalies can also be associated with the analogue and/or digital output (even simultaneously) in the form of alarms.

An additional alarm can also be associated with the analogue and/or digital output on the input measurement reported at the output; depending on the configuration software settings, this alarm can be triggered when the measurement is above/below a set threshold or between/beyond 2 set thresholds.

**PLEASE NOTE:** in the event of an alarm, the output is set to 21mA or 10.5V depending on the analogue output mode setting (current or voltage) selected via the configuration software.

## Data logging

It is possible to activate the LOG function for data acquisition on a USB flash drive from the configuration software's dedicated menu.

The extension of the log file can be of the following types: .xls, .xlsx, .csv, .txt, .dat, .log and can be changed by simply changing the extension to the file name in the configuration tool's save box. The default extension is text.

The minimum sampling time is 1 second and the maximum is approximately 18 hours.



## TECHNICAL SPECIFICATIONS

### Electrical characteristics



Power supply	10÷40 V <sub>DC</sub> or 20÷28 V <sub>AC</sub> @50/60Hz	
Current consumption	250mA	
Isolation	1.5kV galvanic isolation between inputs, analogue outputs, RS485 and USB interfaces and power supply	
Precision class	0,1% F.S. * for thermocouples ±1°C for cold junction	
Temperature coefficient	<100ppm/°C	
Retransmitted output	Configurable analogue in passive and active current (max. voltage 24V) Power supply for passive sensors: 13V <sub>DC</sub> , 30mA max	
Resolution	16 bits (15 bits + sign for thermocouples)	
Input	Analog*	Temperature: <ul style="list-style-type: none"> <li>• RTD (type 385): Pt100 (-200÷600°C), Pt500 (-100÷600°C), Pt1000 (-100÷600°C), Ni100 (-60÷180°C)</li> <li>• TC type: J (-200÷2000°C), K (-260÷1360°C), R(-40÷1760°C), S(-40÷1760°C), T(-260÷400°C), B(-40÷1820°C), E(-260÷1000°C), N(-260÷1280°C)</li> </ul>
		Input range: -10mV to +70mV
		Potentiometer: resistive value from 1kΩ to 10kΩ Resistance: 400Ω or 4kΩ measurement. 2,3 or 4-wire measurement
* Sampling time	100ms, with configurable averaged input value up to a maximum of 32 samples	
Output	Analog configurable in: <ul style="list-style-type: none"> <li>• Voltage: configurable* 0-10V, minimum load resistance 2kΩ</li> <li>• Current: configurable* 0...20mA, maximum load resistance 600Ω</li> </ul> Digital (relay SPDT 250V <sub>AC</sub> , 5A MAX)	
Communication interface	RS485 Modbus RTU microUSB port	
Visual interface	Status LEDs	

### Communication characteristics

Protocol	Modbus RTU
Baudrate	1200÷115200 bps (default 9600)
Addresses	1÷247 (default 1)
Data format	1 start bit, 8-bit data, NO/ODD/EVEN parity (default NO parity)
Response delay	1÷1000ms
Connection	Via removable terminal, T-BUS or microUSB

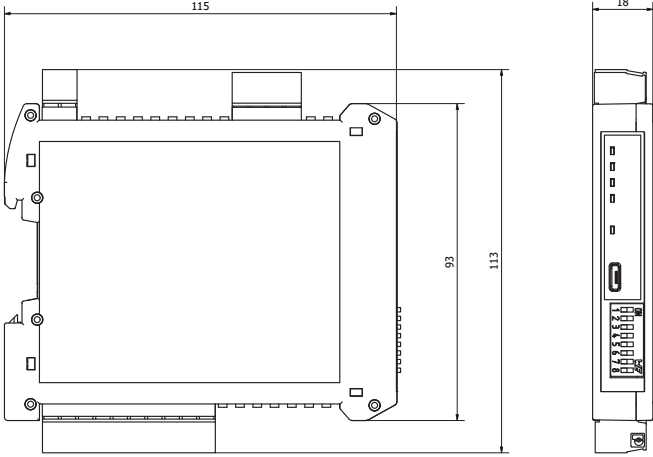

## General data

Working temperature	-15÷60° C
Storage temperature	-40÷85° C
Relative humidity	10÷90% not condensing
Elevation	Up to 2000m a.s.l.
Protection degree	IP20
Measurements	115x113x18 mm 
Weight	116 g
Terminal cable cross-section	0.05÷1.5 mm <sup>2</sup> (30÷14 AWG)
Approvals and certifications	EN61000-6-3 + A1 2011; EN61000-6-2/2005; EN61010-1/2010  
Installation	Inside electrical panels and mounted on a DIN rail

## Order codes

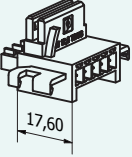
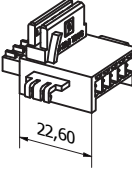
Product	QA-TEMP
Product without logo	QA-TEMP-T-NL
T-BUS	 QA-TBUS-17,5 width 17,6mm   QA-TBUS-22 width 22,6mm



### CONNECTION AND INSTALLATION

The instrument is designed to be installed inside electrical panels and mounted on a DIN rail, with or without the aid of the T-BUS connector for interfacing multiple instruments with reduced cabling.

All connection terminals are shown on the pad print on the product and correspond to the figure below:

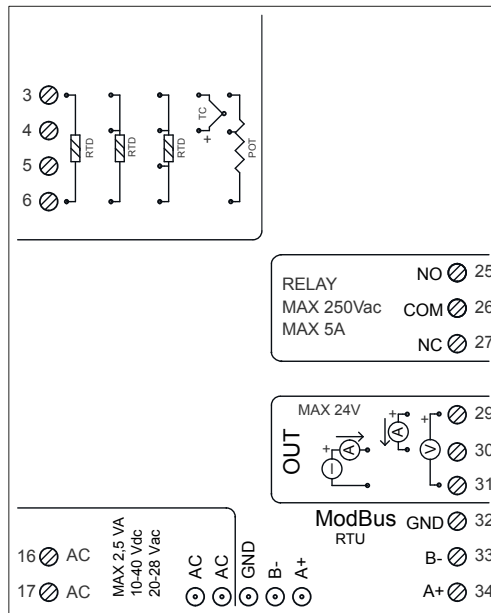

The functionality of the terminals is described below:

<p>16 AC 17 AC</p> <p>MAX 2,5 VA 10-40 Vdc 20-28 Vac</p>	<p>Device power supply</p> <p><b>Please note:</b> Wiring must be protected against short circuits and/or accidental faults</p>
	<p>Analogue input connection:</p> <ul style="list-style-type: none"> <li>- 2-wire RTD sensor: terminals 3 and 6</li> <li>- 3-wire RTD sensor: terminals 3, 4 and 6</li> <li>- 4-wire RTD sensor: terminals 3, 4, 5 and 6</li> <li>- Thermocouple: terminals 3 and 4</li> <li>- Potentiometer: terminals 3, 4 and 6</li> </ul>
	<p>Analogue output connection:</p> <ul style="list-style-type: none"> <li>- Voltage: terminals 31 and 29 (positive)</li> <li>- Active current: terminals 29 (positive) and 30</li> <li>- Passive current: terminals 30 (positive) and 31</li> </ul> <p>Sensor power supply from analogue output: 24Vdc, 30mA maximum</p>
<p>RELAY MAX 250Vac MAX 5A</p> <p>NO 25 COM 26 NC 27</p>	<p>Digital output SPDT 5A / 250V<sub>AC</sub> changeover relay</p> <p>25 normally open (NO) 27 normally closed (NC)</p> <p>The default setting is NO</p> <p>Relay 250V<sub>AC</sub> MAX and 5A MAX</p>



ModBus RTU  
 GND ⊗ 32  
 B- ⊗ 33  
 A+ ⊗ 34

RS485 Modbus RTU connection: terminals 32 (GND), 33 (B-), 34 (A+)

AC ⊗ AC ⊗ | GND ⊗ B- ⊗ A+ ⊗

T-BUS connection (requires optional T-BUS accessory):  
 the T-BUS accessory can be fitted to the module base to provide both power supply and serial communication (see figure below).  
 The number of modules supported by the bus depends on the power supply used (please check the power consumption of the modules)

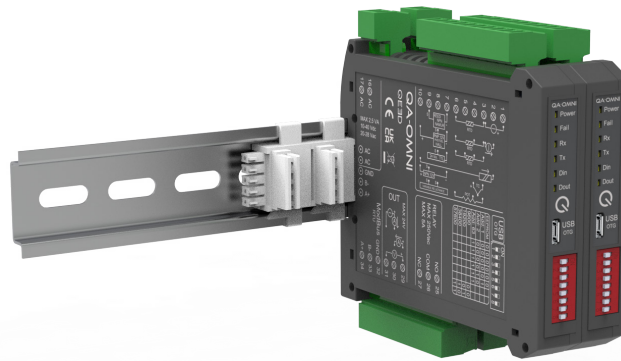

Figure 1: DIN-rail installation with T-BUS

**RS485 bus termination**

To avoid unbalances on the transmission bus, it is advisable to insert a termination resistor at the beginning of the RS-485 bus (typically on the USB-RS485 adapter) and at the end (typically on the last slave - which can also be activated by dip-switch). It is advisable to use 120Ω resistors with 1% tolerance, which corresponds to the typical impedance of RS485 cables.

The following images are for illustrative purposes only:

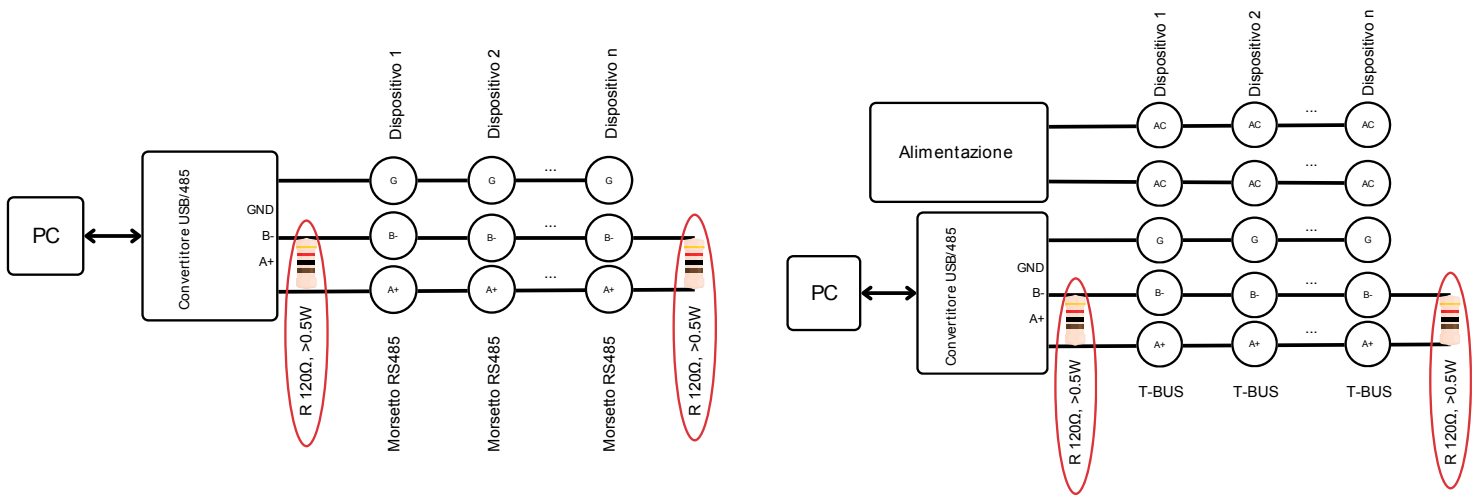

Figure 2: RS485 dynamic bus termination



## STATUS LEDS

Function	Status	Meaning
Power (green)	ON	Powered device
Fail (yellow)	ON	Presence of one or more module anomalies/errors (configurable via <b>Q-WIZARD</b> o or via dedicated registers - see page 16)
RX (red)	Flashing	The system is receiving data on the RS485
TX (red)	Flashing	The system is transmitting data from RS485
Dout (green)	ON	Active digital output

## DATA LOGGING - DATA ACQUISITION

The QA-TEMP is able to provide a series of information regarding the module operation, alarm status, input type, output type, measured data reading, totalisation, period and frequency measurement and module output value on a local USB PENDRIVE type memory (USB KEY) connected to the module via the microUSB port.

The module is equipped with an RTC Real Time Clock powered by a backup battery, allowing the recording of data with year-month-day-hour-min-sec.

Log File example of a J thermocouple, 0-10V output, 1 sample per second

Serial	Data (yyyy-mm-dd) & Time	Status	Analog Input	Analog Output	Input type	Output type
12345678	2014/03/12-14-23-25	0	27.36	359	21	0
12345678	2014/03/12-14-23-26	0	27.36	359	21	0
12345678	2014/03/12-14-23-27	0	27.36	359	21	0
12345678	2014/03/12-14-23-28	0	27.36	359	21	0

**Serial Number:** is the serial number of the module, which allows it to be uniquely identified

**Data & Time:** log time information (year/month/day-hours-min-sec)

**Status:** STATUS register in 16-bit binary mode

- bit [0] = fail global
- bit [1] = alarm
- bit [2] = over range
- bit [3] = under range
- bit [4] = reserved
- bit [5] = Dout status
- bit [6] = fail hw
- bit [7] = fail log
- bit [8] = fail RTC
- bit [9] = fail EEPROM
- bit [10] = fail sensor

**Analog Input:** analogue input information in mA, mV, °C or Ω (as configured)

**Analog Output:** analogue output value in mV or uA (as configured)

**Input type:** is the type of input probe

- 2 = Potentiometer
- 3 = Resistor400Ω-2Wire
- 4 = Resistor400Ω-3Wire
- 5 = Resistor400Ω-4Wire
- 6 = Resistor4000Ω-2Wire
- 7 = Resistor4000Ω-3Wire
- 8 = Resistor4000Ω-4Wire
- 9 = NI100-2Wire
- 10 = NI100-3Wire
- 11 = NI100-4Wire
- 12 = PT100-2Wire
- 13 = PT100-3Wire
- 14 = PT100-4Wire
- 15 = PT500-2Wire



- 16 = PT500-3Wire
- 17 = PT500-4Wire
- 18 = PT1000-2Wire
- 19 = PT1000-3Wire
- 20 = PT1000-4Wire
- 21 = TC J
- 22 = TC K
- 23 = TC R
- 24 = TC S
- 25 = TC T
- 26 = TC B
- 27 = TC E
- 28 = TC N

**Output type:** is the analogue output configuration

- bit [0] = Voltage/Current
- bit [1-2] = analog input
- bit [3] = fail under-range
- bit [4] = fail over-range
- bit [5] = fail HW
- bit [6] = fail log
- bit [7] = fail RTC
- bit [8] = fail EEPROM
- bit [9] = fail alarm
- bit [10-11] = 0 above threshold /1 below threshold /2 outside thresholds /3 inside thresholds
- bit [12] = Manual mode

## PRODUCT FEATURES

The following functions can be configured using the configuration software or the dedicated registers:

### Modbus

Address, baud rate, parities and stop bits are adjustable.

### Inputs/outputs

- Analogue input type and filter on measurement [Reg. 40101, 40103].
- Output type [Reg. 40106] (Possibility to write the register via modbus)
- Input measurement retransmission or manual handling via Modbus RTU on analogue output [Reg. 40106]
- Input and output scaling [Reg. 40107 - 40112]

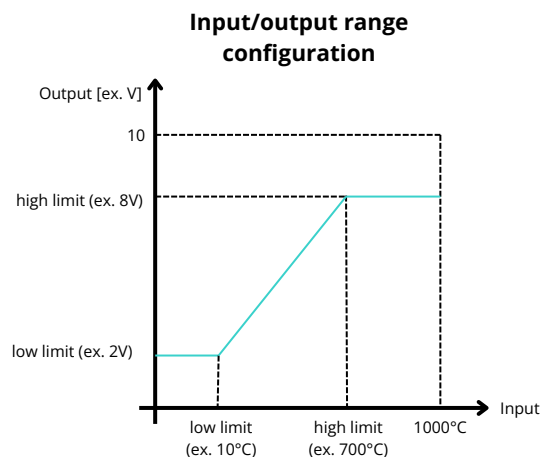

- Status at start-up of digital output [Reg. 40113]



### Analogue output alarm

By configuring the register [40106] it is possible to determine whether an alarm is to be associated with the analogue output (in addition to the value already present on the output itself).

**PLEASE NOTE:** in the event of an alarm, the output is set to 21mA or 10.5V depending on the analogue output mode setting (current or voltage) selected via the configuration software.

### Digital output alarm

By configuring the register [40113] it is possible to define which alarms are to be associated (and possibly the threshold [reg. 40114 - 40116] and hysteresis [reg. 40118] of the variable that triggers the alarm) and whether the alarm is active low/high [reg. 40113].

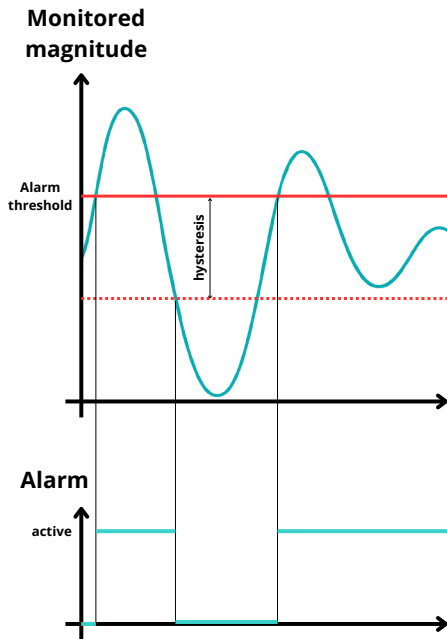

Figure 3: Alarm above threshold

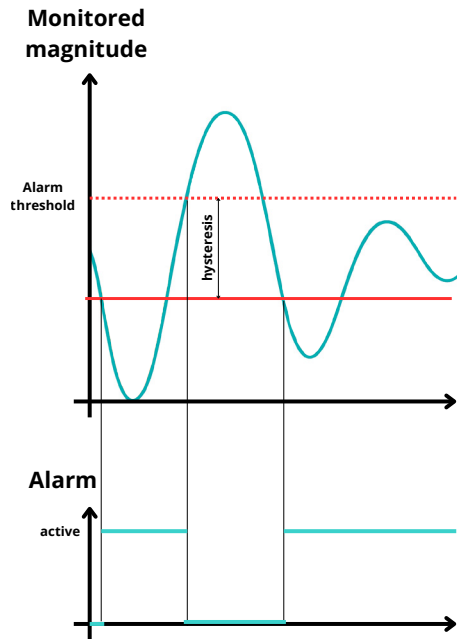

Figure 4: Alarm below threshold

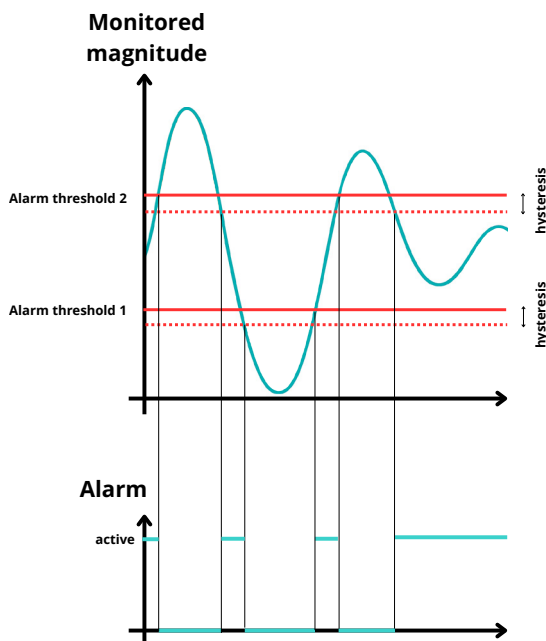

Figure 5: Alarm inside thresholds

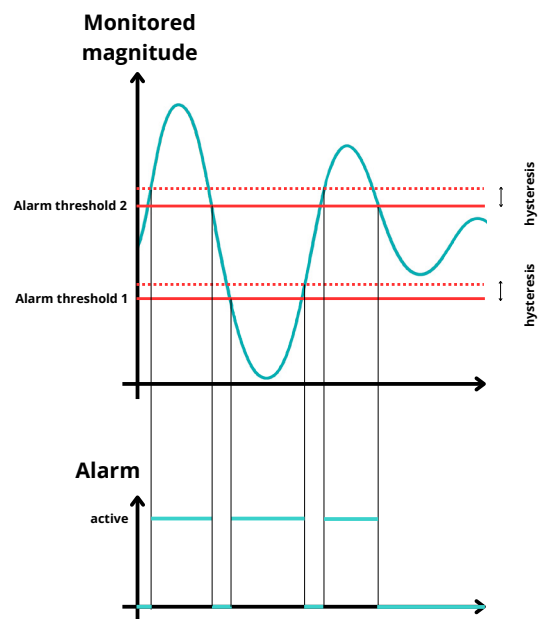

Figure 6: Alarm outside thresholds



## DEVICE CONFIGURATION

### Dip-switch Modbus RTU address and baud rate setting

The DIP switches on the front of the module can be used to change the Modbus RTU address and baud rate. If all DIP switches are set to zero, the module takes the configuration from the EEPROM, otherwise it takes the configuration set by the DIP switches.

USB OTG	ON							
	1	2	3	4	5	6	7	8
EEPROM	0	0	0	0	0	0		
Add: 1	0	0	0	0	0	1		
Add: 2	0	0	0	0	1	0		
Add: 63	1	1	1	1	1	1		
9600							0	0
19200							0	1
38400							1	0
57600							1	1

Addresses greater than 63 and baud rates other than those selected by the DIP switches can be configured using the **Q-WIZARD configuration tool** or the Modbus RTU functions below by acting on the dedicated registers.

Raising DIP switch 1, visible through the hole in the product casing (see figure below), activates the dynamic termination (120Ω) of the Modbus RTU (to be performed only on the last module in the chain - see Figure 2 under RS485 bus termination).

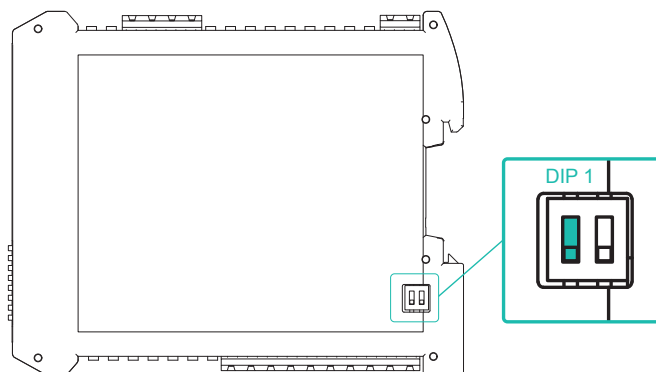

Figure 7: Dip-switch

**PLEASE NOTE:** To activate any DIP switch changes, it is necessary to switch the unit off and on again.

### Functionality configuration

It is possible to connect to the product via an RS485 serial device, such as our Q-USB485, or via the microUSB port.

If the microUSB is used for configuration only, the main power supply from the terminals is not necessary, but it must be present to have all the functions active (real-time monitoring); if configuration is made from the terminals, the power supply must always be present.

The configuration of the module can be done with our **Q-WIZARD** oconfiguration tool or with any third-party Modbus master, by acting on the registers of the card- see page 16.

### Q-WIZARD

Using the **Q-WIZARD configuration tool (downloadable from here)**, all device parameters can be configured by following the simple, intuitive steps.

In addition to the configuration of various parameters, inputs and outputs, the **Q-WIZARD** also allows real-time monitoring of device variables.



### Third-party Modbus Master

Alternatively, the product can communicate directly with a third-party Modbus RTU Master using the communication settings according to the DIP switch configuration (when using microUSB the DIP switch settings are irrelevant).

The communication protocol supported is Modbus RTU Slave:

- Modbus RTU connections: A+ and B- according to Modbus RTU standards
- Supported Modbus RTU functions: 03 hexadecimal (read multiple registers, max 100), 06 hexadecimal (write single), 10 hexadecimal (write multiple registers)
- Modbus RTU address numbering is by convention '1 BASED' (standard), but the physical register is base 0; the logical address, e.g. 40010, corresponds to the physical address #9, as required by Modbus RTU standards

**PLEASE NOTE:** All setting changes of calibration and configuration parameters must be followed by the flash save command 0xC1C0 = Flash settings save command in register 42001; changes of device communication parameters in addition must also be followed by the command 0xC1A0 = Reboot command in register 42001.

In this case, all device configurations are performed by accessing the Modbus RTU register map available in the last chapter of this document using the functions:

- Read holding registers (function 03 hexadecimal)
- Write single holding register (function 06 hexadecimal)
- Write multiple registers (function 10 hexadecimal)

### Function 03 Hexadecimal (Read Holding Registers)

This function is used to read the contents of a contiguous block of holding registers (words). The request frame specifies the source register address and the number of registers to read. A maximum of 120 registers (words) can be read with a single request, unless otherwise specified. The register data in the response message is packaged as two bytes per register (word), with the binary contents right-justified within each byte. For each register, the first byte contains the most significant bits (MSB) and the second byte contains the least significant bits (LSB).

Request Frame			
Description	Length	Value	Comments
Physical address	1 byte	1 to F7 HEX (1 to 247)	
Function code	1 byte	03 HEX	
Starting address	2 bytes	0000 to FFFF HEX	Bytes order: MSB, LSB
Number of registers (N word)	2 bytes	1 to 10 HEX (1 to 16)	Bytes order: MSB, LSB
CRC	2 bytes		

Response frame (right action)			
Description	Length	Value	Comments
Physical address	1 byte	1 to F7 HEX (1 to 247)	
Function code	1 byte	03 HEX	
Required Number of bytes	1 byte	N word * 2	
Register value	N*2 bytes		Bytes order: MSB, LSB
CRC	2 bytes		

Response frame (wrong action)			
Description	Length	Value	Comments
Physical address	1 byte	1 to F7 HEX (1 to 247)	Possible exception: 01: illegal function 02: illegal data address 03: Illegal data value 04: Slave device failure
Function code	1 byte	83 HEX	
Exception code	1 byte	01, 02, 03, 04 (see note)	
CRC	2 bytes		



### Function 06 Hexadecimal (Write Single Holding Register)

This function is used to write a single holding register. The request frame specifies the address of the register (word) to be written and its contents. The correct response is an echo of the request, returned after the contents of the register have been written.

Request frame			
Description	Lenght	Value	Comments
Physical address	1 byte	1 to F7 HEX (1 to 247)	
Function code	1 byte	06 HEX	
Starting address	2 bytes	0000h to FFFF HEX	Bytes order: MSB, LSB
Register value	2 bytes	0000h to FFFF HEX	Bytes order: MSB, LSB
CRC	2 bytes		

Response frame (right action)			
Description	Lenght	Value	Comments
Physical address	1 byte	1 to F7 HEX (1 to 247)	
Function code	1 byte	06 HEX	
Starting address	2 bytes	0000h to FFFF HEX	Bytes order: MSB, LSB
Register value	2 bytes	0000h to FFFF HEX	Bytes order: MSB, LSB
CRC	2 bytes		

Response frame (wrong action)			
Description	Lenght	Value	Comments
Physical address	1 byte	1 to F7 HEX (1 to 247)	Possible exception: 01: illegal function 02: illegal data address 03: Illegal data value 04: Slave device failure
Function code	1 byte	86 HEX	
Exception code	1 byte	01, 02, 03, 04 (see note)	
CRC	2 bytes		



### Function 10 Hexadecimal (Write Multiple Registers)

This function is used to write a block of contiguous registers (maximum of 2). The required values to be written are specified in the data field of the request. The data is packed as two bytes per register.

A correct response returns the function code, the starting address and the number of registers written.

Request frame			
Description	Lenght	Value	Comments
Physical address	1 byte	1 to F7 HEX (1 to 247)	
Function code	1 byte	10 HEX	
Starting address	2 bytes	0000 to FFFF HEX	Bytes order: MSB, LSB
Number of registers (N word)	2 bytes	0001 to 0078 HEX	Bytes order: MSB, LSB
Byte counting	1 byte	N word * 2	
Register value	N * 2 bytes	value	Bytes order: MSB, LSB
CRC	2 bytes		

Response frame (right action)			
Description	Lenght	Value	Comments
Physical address	1 byte	1 to F7 HEX (1 to 247)	
Function code	1 byte	10 HEX	
Starting address	2 bytes	0000 to FFFF HEX	Bytes order: MSB, LSB
Number of registers (N word)	2 bytes	0001 to 0078 HEX	Bytes order: MSB, LSB
CRC	2 bytes		

Response frame (wrong action)			
Description	Lenght	Value	Comments
Physical address	1 byte	1 to F7 HEX (1 to 247)	Possible exception: 01: illegal function 02: illegal data address 03: Illegal data value 04: Slave device failure
Function code	1 byte	90 HEX	
Exception code	1 byte	01, 02, 03, 04 (see note)	
CRC	2 bytes		

## FIRMWARE UPDATE

Using a standard pendrive to hold the file and a micro-USB OTG cable, the product is ready for firmware updates via the USB port.

To update the firmware, simply remove power from the module, insert the pendrive on the card with the file on it and restore the power supply. At this point the card will automatically download the file and update the firmware without changing the settings during programming.

The FAIL LED will flash during the update phase.



## REGISTER MAP

Default values are in **bold**.

Address Modbus	Description	Register Type	R/W	Default	Range
40001	Machine ID	UShort [16b]	R	10	
40002	Firmware ID	UShort [16b]	R		
40003	Unique ID	UInt [32b-MSW]	R		
40005	Status: bit[0] = Fail global bit[1] = alarm bit[2] = Fail over-range based on magnitude selected to be reflected on analog output bit[3] = Fail under-range based on magnitude selected to be reflected on analog output bit[4] = reserved bit[5] = Dout status bit[6] = Fail HW (internal communication problem between uCs) bit[7] = Fail log bit[8] = Fail RTC bit[9] = Fail EEPROM bit[10] = Fail sensor	UShort [16b]	R		
40006	Input Value normalized	Short [16b]	R		0...10000
40009	Output Value [mV or uA] (Possibility to write the register only if bit[12] reg.40106 is = 1)	UShort [16b]	R/W		0...65535
40010	Input Value	Float [32b-LSW]	R		
40016	Cold Junction Temperature	Float [32b-LSW]	R		
40018	TC uV readed	Float [32b-LSW]	R		
40020	Digital output: bit[1] = OFF/ON	UShort [16b]	R/W		
40021	Dip switch status: bit[0] = dip switch position 8 bit[1] = dip switch position 7 ... Bit[7] = dip switch position 1	UShort [16b]	R		
40022	Third wire resistance [Ohm]	Float [32b-LSW]	R		
40101	Analog input type: 2 = Potentiometer 3 = Resistor400-2W 4 = Resistor400-3W 5 = Resistor400-4W 6 = Resistor4000-2W 7 = Resistor4000-3W 8 = Resistor4000-4W 9 = NI100-2W 10 = NI100-3W 11 = NI100-4W <b>12 = PT100-2W</b> 13 = PT100-3W 14 = PT100-4W 15 = PT500-2W 16 = PT500-3W 17 = PT500-4W 18 = PT1000-2W 19 = PT1000-3W 20 = PT1000-4W 21 = TC J 22 = TC K 23 = TC R 24 = TC S 25 = TC T 26 = TC B 27 = TC E 28 = TC N	UShort [16b]	R/W	12	2...28
40103	Temperature settings: bit[0] = measurement unit <b>0 → °C</b> 1 → °F bit[8-15] = analog filter value (number of sample for the calculation of average value [1-32]. If set 0, then internally forced to 1 samples)	UShort [16b]	R/W	0	



Address Modbus	Description	Register Type	R/W	Default	Range
40106	Analog output settings: bit[0] = Analogue output type: <b>0 → Voltage 0÷10V</b> 1 → Current 0÷20mA bit[1-2] = reserved bit[3] = Fail under-range based on magnitude selected to be reflected on analog output bit[4] = Fail over-range based on magnitude selected to be reflected on analog output bit[5] = Fail HW (internal communication problem between uCs) bit[6] = Fail log bit[7] = Fail RTC bit[8] = Fail EEPROM bit[9] = Alarm on monitored input bit[10-11] = alarm type: <b>0 → over threshold</b> 1 → under threshold 2 → outside thresholds 3 → within thresholds bit[12] = Manual mode <b>0 → OFF</b> 1 → ON	UShort [16b]	R/W	0	
40107	Low limit of input range Lower input value of current matched to low value of analogue output (reg. 40111)	Float [32b-LSW]	R/W	0.0	
40109	High limit of input range Higher input value of current matched to high value of analogue output (reg. 40112)	Float [32b-LSW]	R/W	600	
40111	Low limit of output range [mV or uA] depending on the type of output set Output value corresponding to low input value set in reg. 40107	UShort [16b]	R/W	0	See note <sup>1</sup>
40112	High limit of output range [mV or uA] depending on the type of output set Output value corresponding to high input value set in reg. 40109	UShort [16b]	R/W	10000	See note <sup>1</sup>
40113	Digital Output: bit[1] =Fail under-range based on magnitude selected to be reflected on analog output bit[2] =Fail over-range based on magnitude selected to be reflected on analog output bit[3] =Fail HW (internal communication problem between uCs) bit[4] =Fail log bit[5] =Fail RTC bit[6] =Fail EEPROM bit[7] =Alarm on monitored input bit[8] =reserved bit[9] =reserved bit[10] =Alarm / Fail digital output state: 0 → Low 1 → High	UShort [16b]	R/W	0	
40114	Alarm threshold for “above” and “below” types or first alarm threshold for “within threshold” and “Outside threshold” types	Float [32b-LSW]	R/W	0.0	
40116	Second alarm threshold for “within threshold” and “Outside threshold” types (Second threshold value must be higher than first threshold)	Float [32b-LSW]	R/W	0.0	
40118	Alarm Hysteresis value	Float [32b-LSW]	R/W	0.0	
40120	Modbus address, parity, stopbits: MSB: modbus address (default = 1) LSB: bit[0-1] = parity <b>0 → none</b> 1 → Odd 2 → Even LSB: bit[2] = stop bits <b>0 → 1 stop bit</b> 1 → 2 stop bits	UShort [16b]	R/W	256	
40121	Baudrate Value: 0 = 1200 1 = 2400 2 = 4800 <b>3 = 9600</b> 4 = 19200 5 = 38400 6 = 57600 7 = 115200	UShort [16b]	R/W	3	0...7
40122	Log mode: bit[1] = <b>disabled</b> /enabled	UShort [16b]	R/W	0	
40123	Log sample time [s]	UShort [16b]	R/W	1	0...65535
40124	Log name (1 <sup>st</sup> and 2 <sup>nd</sup> characters)	UShort [16b]	R/W	0	
40125	Log name (3 <sup>rd</sup> and 4 <sup>th</sup> characters)	UShort [16b]	R/W	0	
40126	Log name (5 <sup>th</sup> and 6 <sup>th</sup> characters)	UShort [16b]	R/W	0	
40127	Log name (7 <sup>th</sup> and 8 <sup>th</sup> characters)	UShort [16b]	R/W	0	
40128	Log name (9 <sup>th</sup> and 10 <sup>th</sup> characters)	UShort [16b]	R/W	0	
40129	Log name (11 <sup>th</sup> and 12 <sup>th</sup> characters)	UShort [16b]	R/W	0	
40130	Log name (13 <sup>th</sup> and 14 <sup>th</sup> characters)	UShort [16b]	R/W	0	



Address Modbus	Description	Register Type	R/W	Default	Range
40131	Log name (15 <sup>th</sup> character)	UShort [16b]	R/W	0	
41001	RTC: year (2000-2099)	UShort [16b]			2000...2099
41002	RTC: month (1-12)	UShort [16b]			1...12
41003	RTC: day month (1-31)	UShort [16b]			1...31
41004	RTC: hour (0-23)	UShort [16b]			1...23
41005	RTC: minute (0-59)	UShort [16b]			0...59
41006	RTC: second (0-59)	UShort [16b]			0...59
42001	Command: 1 = Reboot 2 = Flash settings save 3 = Set factory configuration 4 = Reset Totalizer 5 = Load Totalizer	UShort [16b]			

**Note:**

<sup>1</sup> Limit depends of the setting of bit[0] of register 40106

- 0...10000 if bit[0] = 0
- 0...20000 if bit[0] = 1

**LEGEND:**

Short [16b] = Signed Short (16 bit)  
UShort [16b] = Unsigned Short (16 bit)

Long [32b-MSW] = Signed Long (32 bit - MSW First Register)  
Long [32b-LWS] = Signed Long (32 bit - LSW First Register)  
ULong [32b-LSW] = Unsigned Long (32 bit - LSW First Register)  
ULong [32b] = Unsigned Long (32 bit)

Float [32b-MSW] = Float (32 bit - MSW First Register)  
Float [32b-LSW] = Float (32 bit - LSW First Register)

UInt [16b] = Unsigned Integer (16 bit)  
UInt [32b-MSW] = Unsigned Integer (32 bit - MSW First Register)  
Int [64b-LSW] = Signed Long Long (64 bit - LSW First Register)



**D.E.M. SpA**

Zona Ind. Villanova 20  
32013 Longarone (BL)  
ITALIA

[www.dem-it.com](http://www.dem-it.com)  
[www.qeed.it](http://www.qeed.it)

As standards, specifications, and design change from time to time, please ask for confirmation of the information given in this publication.