

QE-8DI



Visit the QE-8DI page  
for news, updates and downloads



**CONTENTS**

Product overview .....	3
Technical specifications .....	4
Electrical characteristics .....	4
Communication characteristics .....	4
General data .....	5
Order codes .....	5
Connection and installation .....	6
RS485 bus termination .....	7
Status LEDs .....	8
Product features .....	8
Modbus .....	8
Digital inputs .....	8
Status memory for totalizers .....	8
Device Configuration .....	8
Dip-switch Modbus RTU address and baud rate setting .....	8
Functionality configuration .....	8
Q-WIZARD .....	9

Third-party Modbus Master .....	9
Function 03 Hexadecimal (Read Holding Registers) .....	10
Function 06 Hexadecimal (Write Single Holding Register) .....	11
Function 10 Hexadecimal (Write Multiple Registers) .....	12
Firmware update .....	12
Register map .....	13



## SAFETY WARNINGS AND CAUTIONS

The following warnings and cautions must be observed to ensure personal safety and prevent damage.



**Death** or **serious injury** may result from failure to heed this warning.



It is necessary to comply with national regulations when installing and picking materials for power lines.



**Material damage** or **serious personal injury** may result from failure to heed this warning.



Repairs and modifications must be carried out only by the manufacturer. It is forbidden to open the case and make any changes to the device. Tampering with the device will invalidate the warranty.



The manufacturer **declines all responsibility** for electrical safety in the event of improper use of the equipment.



It is essential to read the entire contents of this manual before carrying out any work.



The product described in this document may only be used for the specified application. The maximum performance data and environmental conditions specified in the product data sheet must be observed. Proper transport and storage, as well as professional assembly, installation, handling and maintenance are required for the correct and safe operation of the device.



Before commissioning, make sure that:

- the maximum values for all connections are not exceeded; refer to the product data sheet;
- the connection cables are not damaged or live during wiring;
- the direction of current flow and phase rotation are correct.

Use under ambient conditions other than those specified, application of signals or voltages other than those specified, may cause significant deviations from the specified measurement tolerances, which may be irreversible.

During installation, ensure that a switch or circuit-breaker is near the product and easily accessible.



Although the contents of this document have been checked for accuracy, it may contain errors or inconsistencies and we cannot guarantee its completeness or accuracy.

The unit must be uninstalled if safe operation can no longer be guaranteed (e.g. visible damage). Disconnect all connections in this case. The unit should be returned to the manufacturer or to an authorised service centre for repair.



This document is subject to periodic revision and updating. QEED reserves the right to make changes to the product and/or its technical documentation at any time in the interests of continuous quality improvement. Always consult the latest version of the documentation available on the website:



**WARNING:** High-intensity magnetic fields may alter the values measured by the transformer. Avoid installation near: permanent magnets, electromagnets, or iron masses. If irregularities are detected, reposition or move the unit to a more suitable location.

[www.qeed.it](http://www.qeed.it)

If you find any errors or missing information in this document, please notify us by e-mail to:

[technical@qeed.it](mailto:technical@qeed.it)



Failure to observe the warnings may result in damage to the equipment or failure to operate as intended.



Disposal of waste electrical and electronic equipment (applicable in the European Union and other countries with separate collection). The symbol on the product or its packaging indicates that the product should not be treated as household waste. Instead, it will be handed over to an authorised collection point for the recycling of electrical and electronic waste. Ensuring that the product is disposed of properly will prevent potential negative effects on the environment and human health, which could otherwise be caused by inappropriate waste management of the product. Recycling materials helps to conserve natural resources. For further information, please contact your local authority, waste disposal service or the retailer from whom you purchased the product.



Please note that the information on the nameplate must be observed.





## PRODUCT OVERVIEW

The QE-8DI is a slave I/O module equipped with 8 opto-isolated digital inputs. All inputs can be set as counters or simple contacts, with a 5V auxiliary output for dry contact detection and GND relose for active contacts. The maximum number of counts is  $2^{32}$  and an underflow/overflow flag is provided to signal when the maximum number of counts is reached.

It can run on both AC and DC power.

It has full galvanic isolation between power supply, serial and USB interface and its inputs.

Power/error/communication/output status LEDs are on the front of the case.

RS485 serial interface for communication with Modbus RTU protocol, either from the [Q-WIZARD configuration tool \(download at link\)](#) or with third party Modbus masters by acting on register map registers.

Ready for DIN rail mounting with T-BUS terminal (optional) for fast connection with hot insertion/removal option.

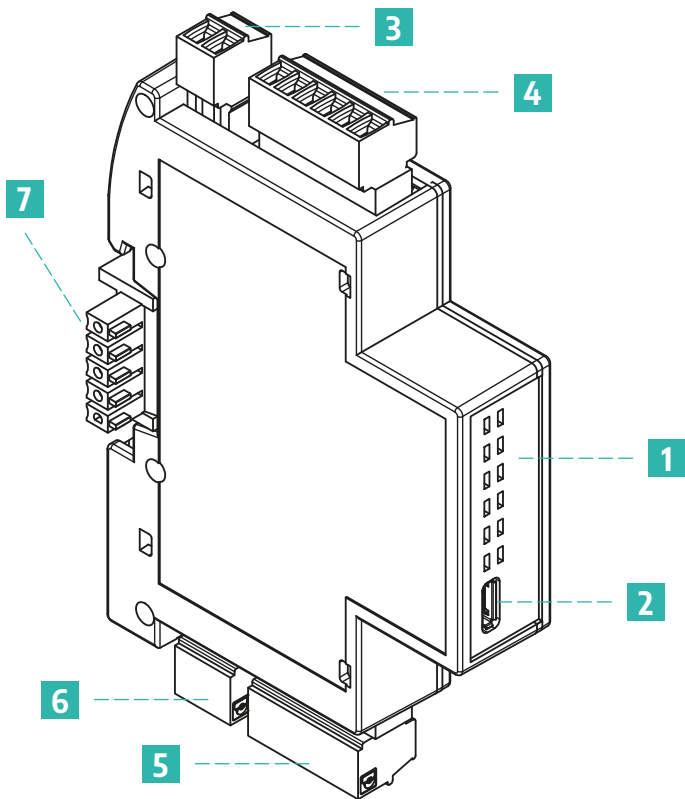

- 1 Status LEDs
- 2 MicroUSB Port
- 3 Power supply terminals
- 4 Input terminals
- 5 Input terminals
- 7 RS485 Modbus RTU terminals
- 8 T-BUS terminal for both power supply and Modbus RTU communication (optional)



## TECHNICAL SPECIFICATIONS

### Electrical characteristics



Power supply	10÷40 V <sub>DC</sub> or 19÷28 V <sub>AC</sub> @50/60Hz
Current consumption	100mA max
Isolation	RS485 serial interface, USB interface and power supply are galvanically isolated from each other at 1.5 kV
Input	#8 digital inputs, PNP type with negative ground, 32-bit counter and maximum sampling rate Input voltage range for active inputs 12-24 V <sub>DC</sub> 12 V terminal presence for dry contact detection
Communication interface	RS485 Modbus RTU microUSB port
Visual interface	Status LEDs

### Communication characteristics

Protocol	Modbus RTU
Baudrate	1200÷115200 bps (default 9600)
Addresses	1÷247 (default 1)
Data format	1 start bit, 8-bit data, NO/ODD/EVEN parity (default NO parity)
Response delay	1÷1000ms
Connection	Via removable terminal, T-BUS or microUSB

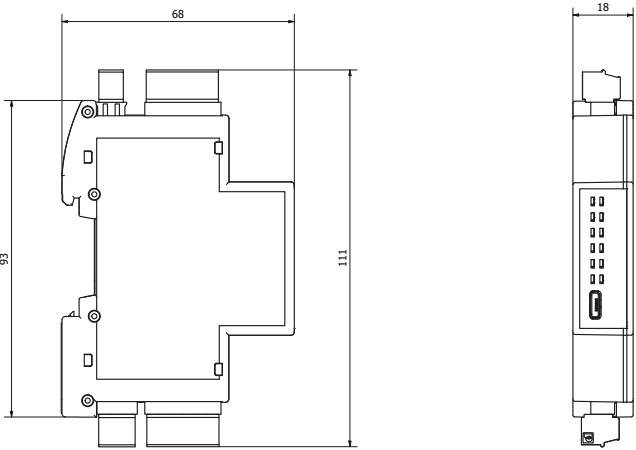

### General data

Working temperature	-15÷60° C
Storage temperature	-40÷85° C
Relative humidity	10÷90% not condensing
Elevation	Up to 2000m a.s.l.
Protection degree	IP20
Measurements	111x68x18 mm 
Weight	63 g
Terminal cable cross-section	0.05÷1.5 mm <sup>2</sup> (30÷14 AWG)
Approvals and certifications	EN61000-6-3 + A1 2011; EN61000-6-2/2005; EN61010-1/2010 
Installation	Inside electrical panels and mounted on a DIN rail

### Order codes

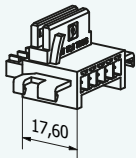
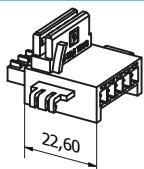
Product	QE-8DI
Product without logo	QE-8DI-T-NL
T-BUS	 QA-TBUS-17,5 width 17,6mm
	 QA-TBUS-22 width 22,6mm



### CONNECTION AND INSTALLATION

For the connection of several instruments with reduced wiring, the unit is designed for DIN rail mounting, with or without T-BUS connector. All connection terminals are shown on the pad print on the product and correspond to the figure below:

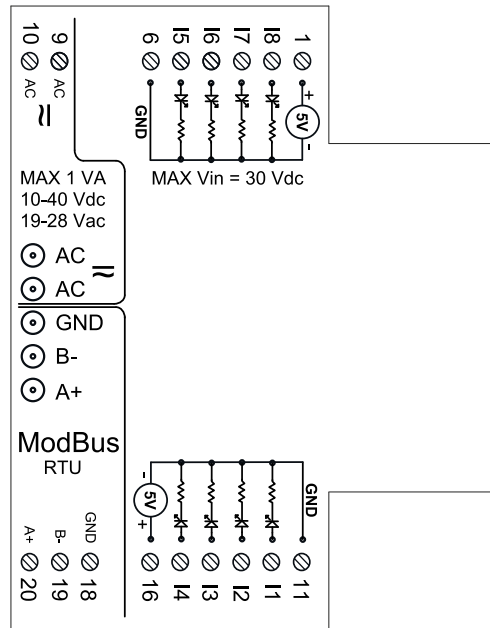

The functionality of the terminals is described below:

<p>MAX 1 VA 10-40 Vdc 19-28 Vac</p> <p>9 ⓪ AC 10 ⓪ AC</p>	<p>Device power supply. <b>Please note:</b> Wiring must be protected against short circuits and/or accidental faults</p>
<p>1 ⓪ + 5V - 18 ⓪ 17 ⓪ 16 ⓪ 15 ⓪ 6 ⓪ GND MAX Vin = 30 Vdc</p>	<p>DIGITAL INPUTS: #8 digital inputs, NPN type with negative ground. On input, it accepts pulses up to 10 kHz from mechanical contact, REED, 5-24 V, PNP.</p>
<p>GND ⓪ 11 I1 ⓪ 11 I2 ⓪ 12 I3 ⓪ 13 I4 ⓪ 14 - 5V + ⓪ 16</p>	
<p>ModBus RTU GND ⓪ 18 B- ⓪ 19 A+ ⓪ 20</p>	<p>RS485 Modbus RTU connection: terminals 32 (GND), 33 (B-), 34 (A+)</p>

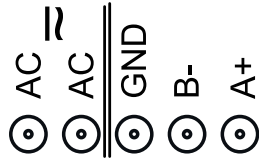

T-BUS connection (requires optional T-BUS accessory):  
 the T-BUS accessory can be fitted to the module base to provide both power supply and serial communication (see figure below).  
 The number of modules supported by the bus depends on the power supply used (please check the power consumption of the modules)



Figure 1: DIN-rail installation with T-BUS

### RS485 bus termination

To avoid unbalances on the transmission bus, it is advisable to insert a termination resistor at the beginning of the RS-485 bus (typically on the USB-RS485 adapter) and at the end (typically on the last slave - which can also be activated by dip-switch). It is advisable to use 120Ω resistors with 1% tolerance, which corresponds to the typical impedance of RS485 cables.

The following images are for illustrative purposes only:

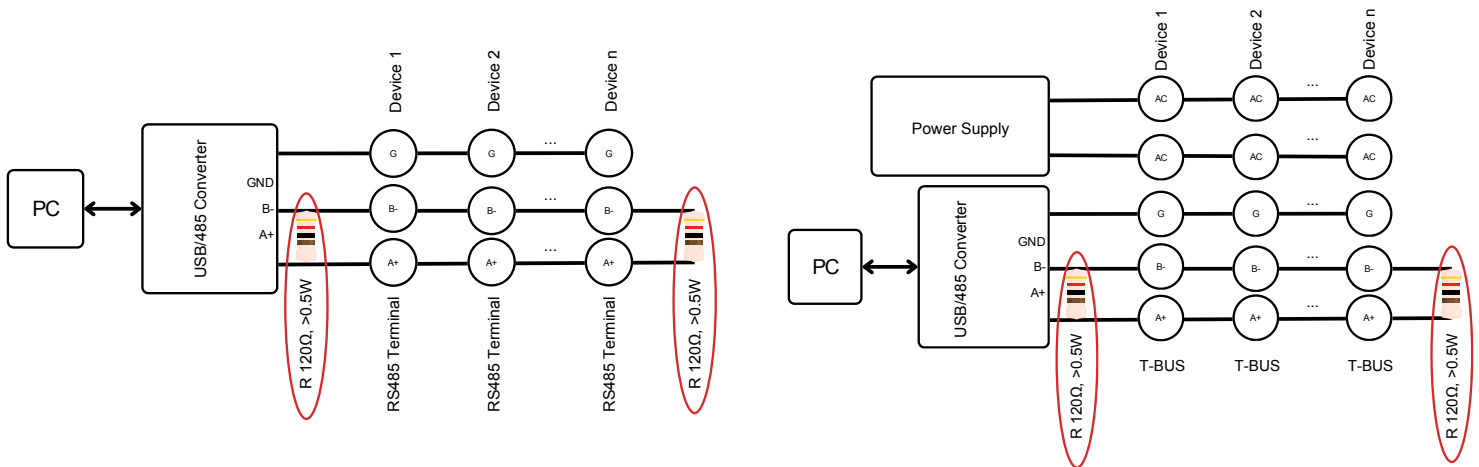

Figure 2: RS485 dynamic bus termination



## STATUS LEDS

Function	Status	Meaning
Power (green)	ON	Powered device
Fail (yellow)	ON	Presence of one or more module anomalies/errors (configurable via <b>Q-WIZARD</b> or via dedicated registers - see page 13)
RX (red)	Flashing	The system is receiving data on the RS485
TX (red)	Flashing	The system is transmitting data on the RS485
I1...I8(green)	ON	Active digital input

## PRODUCT FEATURES

The following functions can be configured using the configuration software or the dedicated registers:

### Modbus

Address, baud rate, parities and stop bits are adjustable.

### Digital inputs

Ability to enable counting on rising or falling edge [reg. 40079], whether to count by incrementing or decrementing [reg. 40092] and 6 filter levels to vary the sampling rate to reduce contact bounce [reg. 40080 - 40087].

### Status memory for totalizers

Possibility of enabling the saving of the states of totalizers in the memory, so that they are retained when the instrument is rebooted [Reg. 40093]

The maximum number of counting operations is  $2^{32}$ .

## DEVICE CONFIGURATION

### Dip-switch Modbus RTU address and baud rate setting

The baud rate can be changed using the DIP switch on one of the two sides of the module. If DIP1 is set to zero, the module adopts the configuration from the EEPROM, otherwise it adopts the configuration set by the DIP switch according to the table:

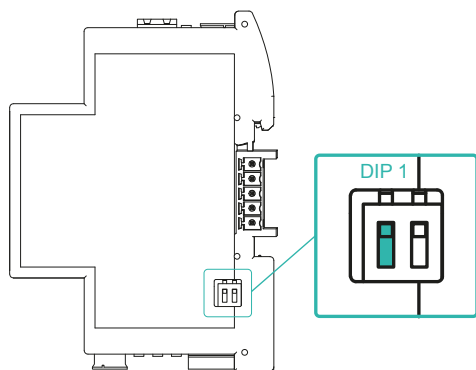

Figure 3: Dip-switch for baudrate setting

DIP1	DIP2	Address	Baudrate
0	x	EEPROM	EEPROM
1	0	1	9600
1	1	1	38400

Addresses other than 1 (default) or baud rates other than those shown in the table can be configured using the **Q-WIZARD configuration software** or the Modbus RTU functions below by acting on the dedicated registers.

### Functionality configuration

It is possible to connect to the product via an RS485 serial device, such as our Q-USB485, or via the microUSB port.

If the microUSB is used for configuration only, the main power supply from the terminals is not necessary, but it must be present to have all the functions active (real-time monitoring); if configuration is made from the terminals, the power supply must always be present.

The configuration of the module can be done with our **Q-WIZARD configuration tool** or with any third-party Modbus master, by acting on the registers of the card- see page 13.



## Q-WIZARD

Using the **Q-WIZARD interface tool (downloadable from here)** all device parameters can be configured by following the simple, intuitive steps. In addition to the configuration of various parameters, inputs and outputs, the **Q-WIZARD** also allows real-time monitoring of device variables.

## Third-party Modbus Master

Alternatively, the product can communicate directly with a third-party Modbus RTU Master using the communication settings according to the DIP switch configuration (when using microUSB the DIP switch settings are irrelevant).

The communication protocol supported is Modbus RTU Slave:

- Modbus RTU connections: A+ and B- according to Modbus RTU standards
- Supported Modbus RTU functions: 03 hexadecimal (read multiple registers, max 100), 06 hexadecimal (write single), 10 hexadecimal (write multiple registers)
- Modbus RTU address numbering is by convention '1 BASED' (standard), but the physical register is base 0; the logical address, e.g. 40010, corresponds to the physical address #9, as required by Modbus RTU standards

**PLEASE NOTE:** All setting changes of calibration and configuration parameters must be followed by the flash save command 0xC1C0 = Flash settings save command in register 40121; changes of device communication parameters in addition must also be followed by the command 0xC1A0 = Reboot command in register 40121.

In this case, all device configurations are performed by accessing the Modbus RTU register map available in the last chapter of this document using the functions:

- Read holding registers (function 03 hexadecimal)
- Write single holding register (function 06 hexadecimal)
- Write multiple registers (function 10 hexadecimal)



### Function 03 Hexadecimal (Read Holding Registers)

This function is used to read the contents of a contiguous block of holding registers (words). The request frame specifies the source register address and the number of registers to read. A maximum of 120 registers (words) can be read with a single request, unless otherwise specified. The register data in the response message is packaged as two bytes per register (word), with the binary contents right-justified within each byte. For each register, the first byte contains the most significant bits (MSB) and the second byte contains the least significant bits (LSB).

Request Frame			
Description	Length	Value	Comments
Physical address	1 byte	1 to F7 HEX (1 to 247)	
Function code	1 byte	03 HEX	
Starting address	2 bytes	0000 to FFFF HEX	Bytes order: MSB, LSB
Number of registers (N word)	2 bytes	1 to 10 HEX (1 to 16)	Bytes order: MSB, LSB
CRC	2 bytes		

Response frame (right action)			
Description	Length	Value	Comments
Physical address	1 byte	1 to F7 HEX (1 to 247)	
Function code	1 byte	03 HEX	
Required Number of bytes	1 byte	N word * 2	
Register value	N*2 bytes		Bytes order: MSB, LSB
CRC	2 bytes		

Response frame (wrong action)			
Description	Length	Value	Comments
Physical address	1 byte	1 to F7 HEX (1 to 247)	Possible exception: 01: illegal function 02: illegal data address 03: Illegal data value 04: Slave device failure
Function code	1 byte	83 HEX	
Exception code	1 byte	01, 02, 03, 04 (see note)	
CRC	2 bytes		



**Function 06 Hexadecimal** (Write Single Holding Register)

This function is used to write a single holding register. The request frame specifies the address of the register (word) to be written and its contents. The correct response is an echo of the request, returned after the contents of the register have been written.

Request frame			
Description	Lenght	Value	Comments
Physical address	1 byte	1 to F7 HEX (1 to 247)	
Function code	1 byte	06 HEX	
Starting address	2 bytes	0000h to FFFF HEX	Bytes order: MSB, LSB
Register value	2 bytes	0000h to FFFF HEX	Bytes order: MSB, LSB
CRC	2 bytes		

Response frame (right action)			
Description	Lenght	Value	Comments
Physical address	1 byte	1 to F7 HEX (1 to 247)	
Function code	1 byte	06 HEX	
Starting address	2 bytes	0000h to FFFF HEX	Bytes order: MSB, LSB
Register value	2 bytes	0000h to FFFF HEX	Bytes order: MSB, LSB
CRC	2 bytes		

Response frame (wrong action)			
Description	Lenght	Value	Comments
Physical address	1 byte	1 to F7 HEX (1 to 247)	Possible exception: 01: illegal function 02: illegal data address 03: Illegal data value 04: Slave device failure
Function code	1 byte	86 HEX	
Exception code	1 byte	01, 02, 03, 04 (see note)	
CRC	2 bytes		



### Function 10 Hexadecimal (Write Multiple Registers)

This function is used to write a block of contiguous registers (maximum of 2). The required values to be written are specified in the data field of the request. The data is packed as two bytes per register.

A correct response returns the function code, the starting address and the number of registers written.

Request frame			
Description	Lenght	Value	Comments
Physical address	1 byte	1 to F7 HEX (1 to 247)	
Function code	1 byte	10 HEX	
Starting address	2 bytes	0000 to FFFF HEX	Bytes order: MSB, LSB
Number of registers (N word)	2 bytes	0001 to 0078 HEX	Bytes order: MSB, LSB
Byte counting	1 byte	N word * 2	
Register value	N * 2 bytes	value	Bytes order: MSB, LSB
CRC	2 bytes		

Response frame (right action)			
Description	Lenght	Value	Comments
Physical address	1 byte	1 to F7 HEX (1 to 247)	
Function code	1 byte	10 HEX	
Starting address	2 bytes	0000 to FFFF HEX	Bytes order: MSB, LSB
Number of registers (N word)	2 bytes	0001 to 0078 HEX	Bytes order: MSB, LSB
CRC	2 bytes		

Response frame (wrong action)			
Description	Lenght	Value	Comments
Physical address	1 byte	1 to F7 HEX (1 to 247)	Possible exception: 01: illegal function 02: illegal data address 03: Illegal data value 04: Slave device failure
Function code	1 byte	90 HEX	
Exception code	1 byte	01, 02, 03, 04 (see note)	
CRC	2 bytes		

## FIRMWARE UPDATE

Using a standard pendrive to hold the file and a micro-USB OTG cable, the product is ready for firmware updates via the USB port.

To update the firmware, simply remove power from the module, insert the pendrive on the card with the file on it and restore the power supply. At this point the card will automatically download the file and update the firmware without changing the settings during programming.

The FAIL LED will flash during the update phase.



## REGISTER MAP

Default values are in **bold**.

Address Modbus	Description	Register Type	R/W	Default
40001	Machine ID	UShort [16b]	R	34
40002	Firmware version	UShort [16b]	R	
40003	Status: bit[0] = fail eeprom calibration bit[1] = fail eeprom configuration bit[2] = fail hw bit[3] = fail log bit[4] = fail rtc bit[5] = fail eeprom bit[6] = fail fram	UShort [16b]	R	
40004	Digital input real-time status: bit[0] = Din 1; ... bit[7] = Din 8	UShort [16b]	R	
40006	DIP switch status: bit[0] = DIP1 ... bit[1] = DIP2	UShort [16b]	R	
40012	Overflow or underflow: bit[0] = Totalizer 1 0 → Totalizer 1 not in overflow/underflow 1 → Totalizer 1 in overflow/underflow bit[1] = Totalizer 2 0 → Totalizer 2 not in overflow/underflow 1 → Totalizer 2 in overflow/underflow ... bit[7] = Totalizer 8 0 → Totalizer 8 not in overflow/underflow 1 → Totalizer 8 in overflow/underflow	UShort [16b]	R/W	0
40015	Totalizer Din 1	ULong [32b-LSW]	R/W	0
40017	Totalizer Din 2	ULong [32b-LSW]	R/W	0
40019	Totalizer Din 3	ULong [32b-LSW]	R/W	0
40021	Totalizer Din 4	ULong [32b-LSW]	R/W	0
40023	Totalizer Din 5	ULong [32b-LSW]	R/W	0
40025	Totalizer Din 6	ULong [32b-LSW]	R/W	0
40027	Totalizer Din 7	ULong [32b-LSW]	R/W	0
40029	Totalizer Din 8	ULong [32b-LSW]	R/W	0
40079	Totalizer counting mode: bit[0] = Din 1 <b>0 → Din 1 rising edge</b> 1 → Din 1 falling edge bit[1] = Din 2 <b>0 → Din 2 rising edge</b> 1 → Din 2 falling edge ... bit[7] = Din 8 <b>0 → Din 8 rising edge</b> 1 → Din 8 falling edge	UShort [16b]	R/W	0
40080	Number of samples for the filter of Din 1 <b>0 = 10 kHz</b> 1 = 5 kHz 5 = 1 kHz 50 = 100 Hz 500 = 10 Hz 5000 = 1 Hz	UShort [16b]	R/W	0
40081	Number of samples for the filter of Din 2 <b>0 = 10 kHz</b> 1 = 5 kHz 5 = 1 kHz 50 = 100 Hz 500 = 10 Hz 5000 = 1 Hz	UShort [16b]	R/W	0



Address Modbus	Description	Register Type	R/W	Default
40082	Number of samples for the filter of Din 3 <b>0 = 10 kHz</b> 1 = 5 kHz 5 = 1 kHz 50 = 100 Hz 500 = 10 Hz 5000 = 1 Hz	UShort [16b]	R/W	0
40083	Number of samples for the filter of Din 4 <b>0 = 10 kHz</b> 1 = 5 kHz 5 = 1 kHz 50 = 100 Hz 500 = 10 Hz 5000 = 1 Hz	UShort [16b]	R/W	0
40084	Number of samples for the filter of Din 5 <b>0 = 10 kHz</b> 1 = 5 kHz 5 = 1 kHz 50 = 100 Hz 500 = 10 Hz 5000 = 1 Hz	UShort [16b]	R/W	0
40085	Number of samples for the filter of Din 6 <b>0 = 10 kHz</b> 1 = 5 kHz 5 = 1 kHz 50 = 100 Hz 500 = 10 Hz 5000 = 1 Hz	UShort [16b]	R/W	0
40086	Number of samples for the filter of Din 7 <b>0 = 10 kHz</b> 1 = 5 kHz 5 = 1 kHz 50 = 100 Hz 500 = 10 Hz 5000 = 1 Hz	UShort [16b]	R/W	0
40087	Number of samples for the filter of Din 8 <b>0 = 10 kHz</b> 1 = 5 kHz 5 = 1 kHz 50 = 100 Hz 500 = 10 Hz 5000 = 1 Hz	UShort [16b]	R/W	0
40092	Totalizer counter direction: bit[0] = Totalizer 1 0 → Totalizer 1 incremental 1 → Totalizer 1 decremental bit[1] = Totalizer 2 0 → Totalizer 2 incremental 1 → Totalizer 2 decremental ... bit[7] = Totalizer 8 0 → Totalizer 8 incremental 1 → Totalizer 8 decremental	UShort [16b]	R/W	0
40093	FRAM settings: bit[14] = 0 = Totalizer status logging in FRAM disable 1 = Totalizer status logging in FRAM enable	UShort [16b]	R/W	0xC000
40094	Modbus address, parity, stopbits: MSB: modbus address (default address = 1) LSB: bit[0-1] = parity <b>0 → none</b> 1 → Odd 2 → Even LSB: bit[2] = stop bits <b>0 → 1 stop bit</b> 1 → 2 stop bits	UShort [16b]	R/W	256



Address Modbus	Description	Register Type	R/W	Default
40095	Baudrate Value: 0 = 1200 1 = 2400 2 = 4800 <b>3 = 9600</b> 4 = 19200 5 = 38400 6 = 57600 7 = 115200	UShort [16b]	R/W	3
40121	Command: 0xC1C0 = Flash setting save command 0xD166 = Dip read command 0xC1A0 = Reboot command	UShort [16b]	R/W	0
40124	S/N part1	UShort [16b]	R	
40125	S/N part2	UShort [16b]	R	
40126	S/N part3	UShort [16b]	R	
40127	Hardware version	UShort [16b]	R	

**LEGEND:**

Short [16b] = Signed Short (16 bit)  
UShort [16b] = Unsigned Short (16 bit)

Long [32b-MSW] = Signed Long (32 bit - MSW First Register)  
Long [32b-LWS] = Signed Long (32 bit - LSW First Register)  
ULong [32b-LSW] = Unsigned Long (32 bit - LSW First Register)  
ULong [32b] = Unsigned Long (32 bit)

Float [32b-MSW] = Float (32 bit - MSW First Register)  
Float [32b-LSW] = Float (32 bit - LSW First Register)

UInt [16b] = Unsigned Integer (16 bit)  
UInt [32b-MSW] = Unsigned Integer (32 bit - MSW First Register)  
Int [64b-LSW] = Signed Long Long (64 bit - LSW First Register)



**D.E.M. SpA**

Zona Ind. Villanova 20  
32013 Longarone (BL)  
ITALIA

[www.dem-it.com](http://www.dem-it.com)  
[www.qeed.it](http://www.qeed.it)

As standards, specifications, and design change from time to time, please ask for confirmation of the information given in this publication.