

QE-RS485-ISOLATOR

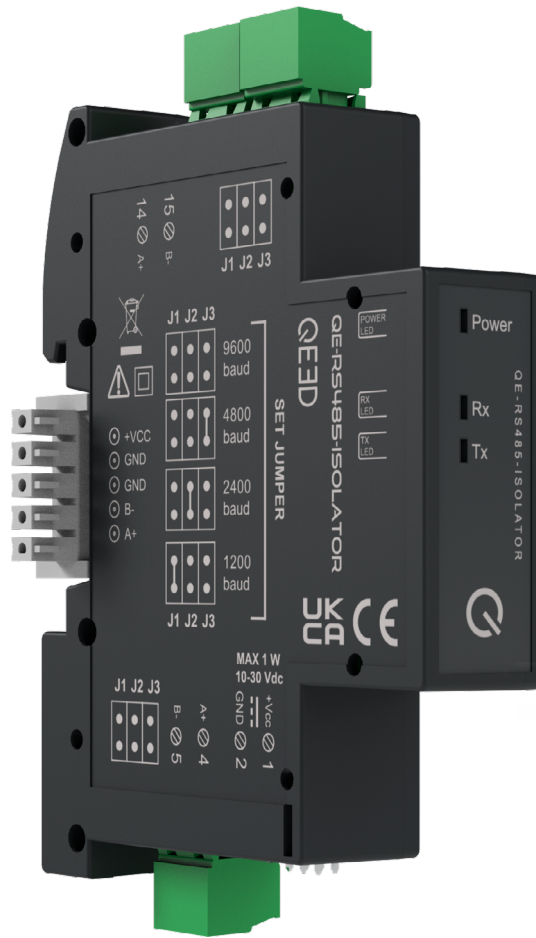

Visit the **QE-RS485-ISOLATOR** page
for news, updates and downloads



CONTENTS

Product overview.....	3
Technical specifications.....	4
Electrical characteristics.....	4
Communication characteristics.....	4
General data.....	5
Order codes.....	5
Connection and installation.....	6
Safety precautions.....	6
Status LEDs.....	7
Baud rate configuration with jumper set.....	7



SAFETY WARNINGS AND CAUTIONS

The following warnings and cautions must be observed to ensure personal safety and prevent damage.



Death or **serious injury** may result from failure to heed this warning.



It is necessary to comply with national regulations when installing and picking materials for power lines.



Material damage or **serious personal injury** may result from failure to heed this warning.



Repairs and modifications must be carried out only by the manufacturer. It is forbidden to open the case and make any changes to the device. Tampering with the device will invalidate the warranty.



The manufacturer **declines all responsibility** for electrical safety in the event of improper use of the equipment.



It is essential to read the entire contents of this manual before carrying out any work.



The product described in this document may only be used for the specified application. The maximum performance data and environmental conditions specified in the product data sheet must be observed. Proper transport and storage, as well as professional assembly, installation, handling and maintenance are required for the correct and safe operation of the device.



Before commissioning, make sure that:

- the maximum values for all connections are not exceeded; refer to the product data sheet;
- the connection cables are not damaged or live during wiring;
- the direction of current flow and phase rotation are correct.

Use under ambient conditions other than those specified, application of signals or voltages other than those specified, may cause significant deviations from the specified measurement tolerances, which may be irreversible.

During installation, ensure that a switch or circuit-breaker is near the product and easily accessible.



Although the contents of this document have been checked for accuracy, it may contain errors or inconsistencies and we cannot guarantee its completeness or accuracy.

The unit must be uninstalled if safe operation can no longer be guaranteed (e.g. visible damage). Disconnect all connections in this case. The unit should be returned to the manufacturer or to an authorised service centre for repair.



This document is subject to periodic revision and updating. QEED reserves the right to make changes to the product and/or its technical documentation at any time in the interests of continuous quality improvement. Always consult the latest version of the documentation available on the website:



WARNING: High-intensity magnetic fields may alter the values measured by the transformer. Avoid installation near: permanent magnets, electromagnets, or iron masses. If irregularities are detected, reposition or move the unit to a more suitable location.

www.qeed.it

If you find any errors or missing information in this document, please notify us by e-mail to:

technical@qeed.it



Failure to observe the warnings may result in damage to the equipment or failure to operate as intended.



Disposal of waste electrical and electronic equipment (applicable in the European Union and other countries with separate collection). The symbol on the product or its packaging indicates that the product should not be treated as household waste. Instead, it will be handed over to an authorised collection point for the recycling of electrical and electronic waste. Ensuring that the product is disposed of properly will prevent potential negative effects on the environment and human health, which could otherwise be caused by inappropriate waste management of the product. Recycling materials helps to conserve natural resources. For further information, please contact your local authority, waste disposal service or the retailer from whom you purchased the product.



Please note that the information on the nameplate must be observed.





PRODUCT OVERVIEW

The QE-RS485-ISOLATOR is an opto-electronically isolated repeater for use on the RS485 serial interface, capable of galvanically separating the two bus signal sections and regenerating the signal itself. This allows transmission distances to be increased by eliminating the limitations of cable resistance and capacitance. Power and communication indicator LEDs are on the front panel.

Ready for DIN rail mounting with T-BUS terminal (optional) for fast connection with hot insertion/removal option.

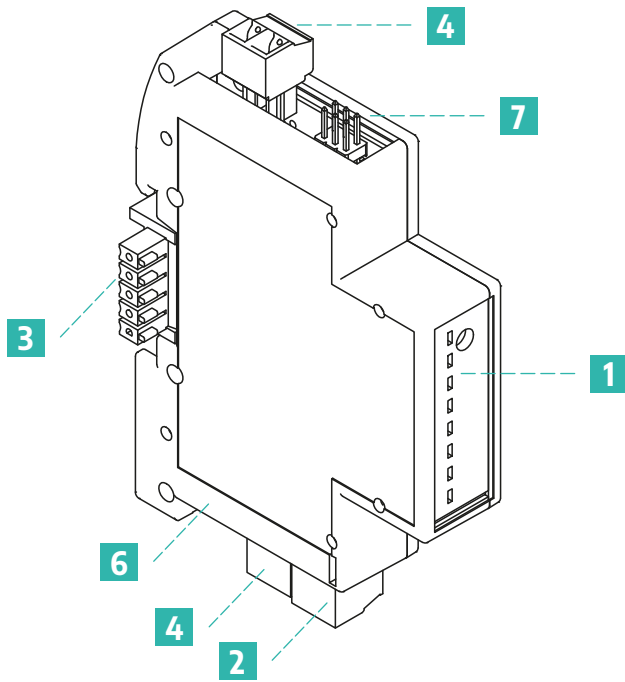

- 1** Status LEDs
- 2** Power supply terminals
- 3** T-BUS terminal for both power supply and Modbus RTU communication (optional)
- 4** RS485 serial interface input terminals
- 5** RS485 serial interface output terminals
- 6** Input baud rate set jumper
- 7** Output baud rate set jumper



TECHNICAL SPECIFICATIONS

Electrical characteristics



Power supply	12V _{DC} ±10%
Current consumption	120mA max
Isolation	3kV (DC) reinforced optoelectronic
Input	RS485 Modbus RTU
Output	RS485 Modbus RTU
Visual interface	Status LEDs

Communication characteristics

Baudrate	1200 ÷ 115200 bps (default 9600)
Addresses	1 ÷ 247 (default 1)
Data format	1 start bit, 8-bit data, NO/ODD/EVEN parity (default NO parity)
Response delay	1 ÷ 1000ms
Connection	Via removable terminal, T-BUS or microUSB

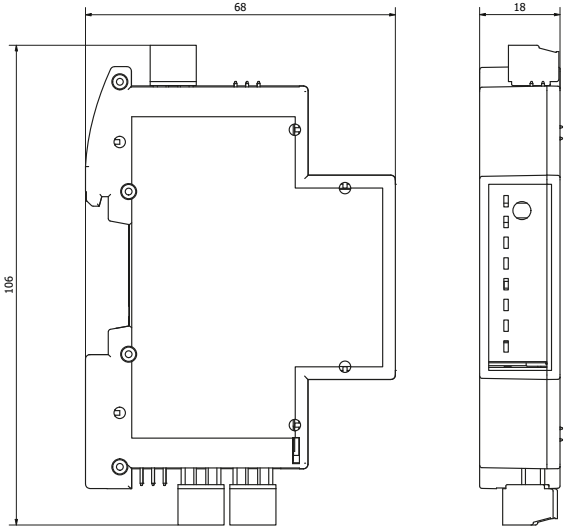

General data

Working temperature	-15÷60° C
Storage temperature	-40÷85° C
Relative humidity	10÷90% not condensing
Elevation	Up to 2000m a.s.l.
Protection degree	IP55
Measurements	106x68x18 mm 
Weight	60 g
Terminal cable cross-section	0.05 ÷ 1.5 mm ² (30 ÷ 14 AWG)
Approvals and certifications	EN61000-6-4/2006 + A1 2011; EN61010-1/2010 
Installation	DIN rail mounting

Order codes

Product	QE-RS485-ISOLATOR
T-BUS	QA-TBUS-22



CONNECTION AND INSTALLATION

The instrument is designed to be DIN-rail mounted, with or without the T-BUS connector for interfacing multiple instruments with reduced wiring.

Safety precautions

- Connect the instrument only after checking that the supply voltage (12V_{dc}) is correct.
- NEVER touch the instrument when it is powered
- Do not bring the instrument into contact with sources of moisture
- In case of malfunctioning or failure, contact authorised personnel describing the anomalies detected
- Always use a cable suitable for serial data transmission.

Below is a description of the terminal functions:

<p>MAX 1 W 10-30 Vdc</p> <p>+Vcc ①  GND ②</p>	<p>Device power supply. Please note: Wiring must be protected against short circuits and/or accidental faults</p>
<p>A+ ④ B- ⑤</p>	<p>RS485 serial input: terminals 4(A+) and 5(B-)</p>
<p>15 ⑬ B- 14 ⑭ A+</p>	<p>RS485 serial output: terminals 14(A+) and 15(B-)</p>
<p>⊙ +VCC ⊙ GND ⊙ GND ⊙ B- ⊙ A+</p>	<p>T-BUS connection (requires optional T-BUS accessory): the T-BUS accessory can be fitted to the module base to provide both power supply and serial communication (see figure below). The number of modules supported by the bus depends on the power supply used (please check the power consumption of the modules)</p>

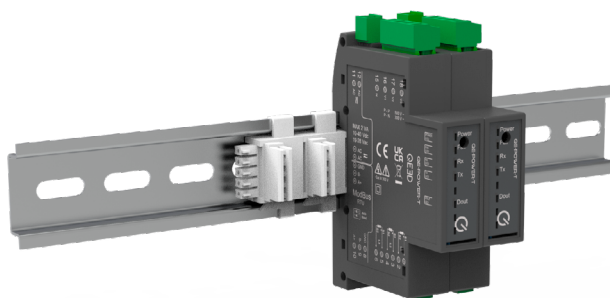

Figure 1: DIN-rail installation with T-BUS



STATUS LEDS

Function	State	Meaning
Power (green)	ON	Powered device
RX (red)	Flashing	The system is receiving data from the RS485
TX (red)	Flashing	The system is transmitting data on RS485

BAUD RATE CONFIGURATION WITH JUMPER SET

The baud rate can be set using the jumpers on the side of the product (supplied as standard in the package), by inserting them in the jumpers J1 - J2 - J3 according to the 'SET JUMPER' diagram shown on the product's pad printing (the configuration must be the same for both jumpers).

