

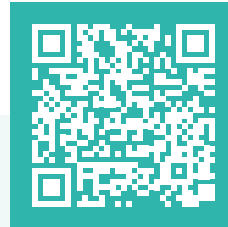

QI-POWER-485 | QI-POWER-485-100 | QI-POWER-485-300



Visit the product page for news, updates and downloads



QI-POWER-485



QI-POWER-485-100



QI-POWER-485-300

CONTENTS

Product overview.....	3
Technical specifications.....	4
Electrical characteristics.....	4
Communication characteristics.....	4
General data.....	4
Order codes.....	5
Connection and installation.....	6
Available measurement.....	7
Product features.....	7
Modbus.....	7
Input/Output.....	7
Device configuration.....	7
Baudrate setting via DIP switch.....	7
Functionality configuration.....	8
Q-WIZARD.....	8
Third-party Modbus Master.....	8
Function 03 Hexadecimal (Read Holding Registers).....	9

Function 06 Hexadecimal (Write Single Holding Register).....	10
Function 10 Hexadecimal (Write Multiple Registers).....	11
Register map.....	12



SAFETY WARNINGS AND CAUTIONS

The following warnings and cautions must be observed to ensure personal safety and prevent damage.



Death or **serious injury** may result from failure to heed this warning.



It is necessary to comply with national regulations when installing and picking materials for power lines.



Material damage or **serious personal injury** may result from failure to heed this warning.



Repairs and modifications must be carried out only by the manufacturer. It is forbidden to open the case and make any changes to the device. Tampering with the device will invalidate the warranty.



The manufacturer **declines all responsibility** for electrical safety in the event of improper use of the equipment.



It is essential to read the entire contents of this manual before carrying out any work.



The product described in this document may only be used for the specified application. The maximum performance data and environmental conditions specified in the product data sheet must be observed. Proper transport and storage, as well as professional assembly, installation, handling and maintenance are required for the correct and safe operation of the device.



Before commissioning, make sure that:

- the maximum values for all connections are not exceeded; refer to the product data sheet;
- the connection cables are not damaged or live during wiring;
- the direction of current flow and phase rotation are correct.

During installation, ensure that a switch or circuit-breaker is near the product and easily accessible.

The unit must be uninstalled if safe operation can no longer be guaranteed (e.g. visible damage). Disconnect all connections in this case. The unit should be returned to the manufacturer or to an authorised service centre for repair.

Use under ambient conditions other than those specified, application of signals or voltages other than those specified, may cause significant deviations from the specified measurement tolerances, which may be irreversible.



WARNING: High-intensity magnetic fields may alter the values measured by the transformer. Avoid installation near: permanent magnets, electromagnets, or iron masses. If irregularities are detected, reposition or move the unit to a more suitable location.



Although the contents of this document have been checked for accuracy, it may contain errors or inconsistencies and we cannot guarantee its completeness or accuracy.



This document is subject to periodic revision and updating. QEED reserves the right to make changes to the product and/or its technical documentation at any time in the interests of continuous quality improvement. Always consult the latest version of the documentation available on the website:

www.qeed.it

If you find any errors or missing information in this document, please notify us by e-mail to:

technical@qeed.it



Failure to observe the warnings may result in damage to the equipment or failure to operate as intended.



Disposal of waste electrical and electronic equipment (applicable in the European Union and other countries with separate collection). The symbol on the product or its packaging indicates that the product should not be treated as household waste. Instead, it will be handed over to an authorised collection point for the recycling of electrical and electronic waste. Ensuring that the product is disposed of properly will prevent potential negative effects on the environment and human health, which could otherwise be caused by inappropriate waste management of the product. Recycling materials helps to conserve natural resources. For further information, please contact your local authority, waste disposal service or the retailer from whom you purchased the product.



Please note that the information on the nameplate must be observed.





PRODUCT OVERVIEW

The QI-POWER-485-(xxx) (in its three versions 50A, 100A and 300A) is a single-phase network analyser capable of measuring current and AC/DC T_{RMS} voltage without the need for external current transformers. The accuracy class is 0.5% of F.S.

The unit provides instantaneous values of I_{rms} , V_{rms} , Power (active, reactive and apparent), V_{pk} , I_{pk} , Frequency, $\cos\phi$, THD and cumulative values of total, absorbed and produced energy.

The product is powered by an external 12V_{DC} or 24V_{DC} power supply.

The input voltage isolation is 4kV.

The safety category is Cat III up to 600V (bare conductor) and Cat II up to 1000V (insulated conductor).

RS485 serial interface for communication with Modbus RTU protocol, either from the [Q-WIZARD configuration tool \(download at link\)](#), or with third party Modbus masters by acting on register map registers.

Mounting accessories supplied as standard for DIN rail mounting.

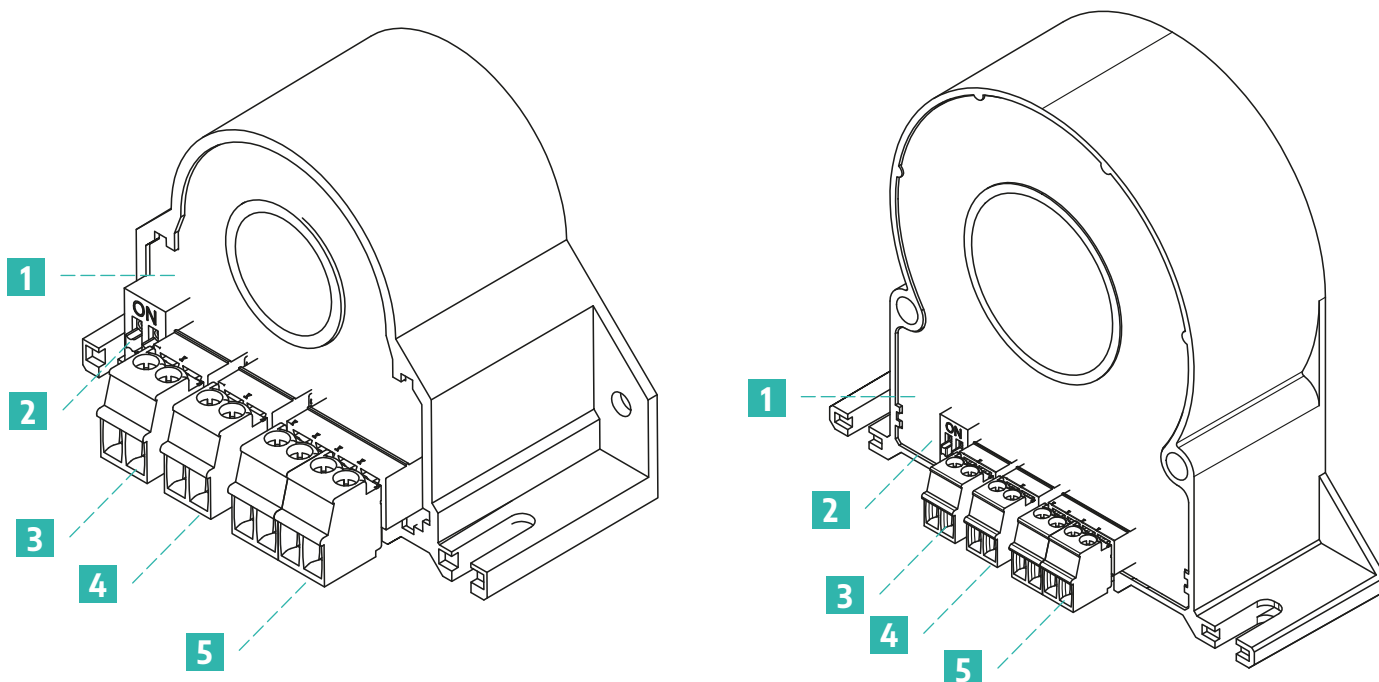

- 1** Status LED:
 - Off: product not powered
 - Steady yellow: product powered
 - Flashing yellow: communication in progress
- 2** DIP switch for Modbus RTU baud rate setting
- 3** Screw terminals for voltage input V- (N)
- 4** Screw terminals for voltage input V+ (L)
- 5** Screw terminals for power supply and serial communication



TECHNICAL SPECIFICATIONS

Electrical characteristics

	QI-POWER-485	QI-POWER-485-100	QI-POWER-485-300
Power supply	9÷30V _{DC} with reverse polarity and overtemperature protection		
Current consumption	1,3 W		
Measurable AC/DC current range	5÷50 A	10÷100 A	30÷300 A
Max. measuring voltage	800V _{AC} , 1000V _{DC}		
Measurement type	TRMS(AC)/DC		
Measurement frequency	DC or 1÷400Hz		
Accuracy class @25°C up 200Hz	Voltage, Current, Active Power: <0,5% F.S. Frequency: ±0,1 Hz Energy: ±1% on reading V _{peak} , I _{peak} : ± 5% F.S.		
Crest factor	1.8 (on current measurement)		
Sampling rate	11 ksample/s		
Input impedance	1 MΩ		
Overvoltage category	Cat III up to 600V Cat II up to 1000V		
Isolation	3kV on bare cable for current measurement 4kV for voltage measurement (reinforced insulation to power supply and RS485 serial interface)		
THD	Available for measured currents greater than 15% of F.S.		
Communication interface	RS485 Modbus RTU		

Communication characteristics

Protocol	Modbus RTU
Baudrate	1200÷115200 bps (default 9600)
Addresses	1÷247 (default 1)
Data format	1 start bit, 8-bit data, NO/ODD/EVEN parity (default NO parity)
Response delay	1÷1000ms
Connection	Via removable 4-pin terminal

General data

Working temperature	-15÷60° C
Storage temperature	-40÷85° C
Relative humidity	10÷90% not condensing
Elevation	Up to 2000 a.s.l.
Temperature coefficient	< 200ppm/°C
Protection degree	IP20



Measurements

QI-POWER-485 | QI-POWER-485-100 42x63x47 mm

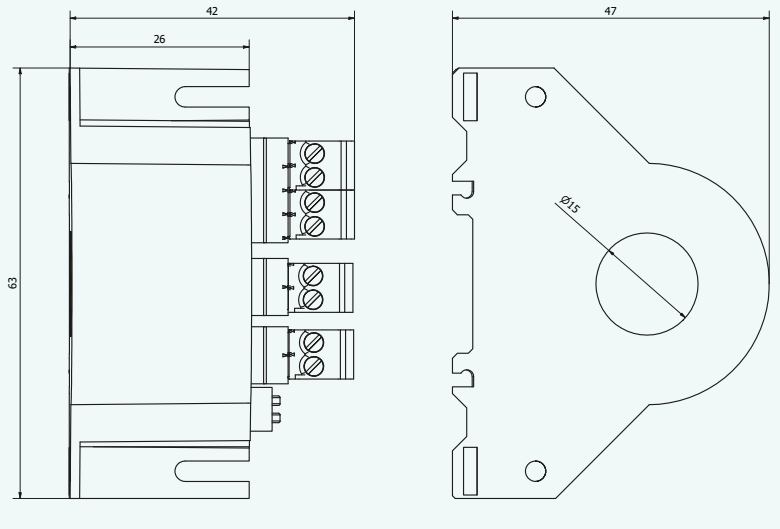

QI-POWER-485-300 45x100x90 mm

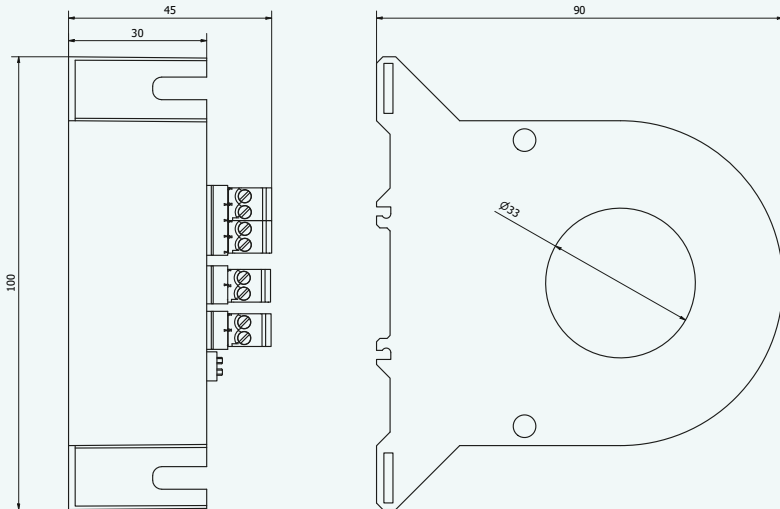

Weight	QI-POWER-485-50 QI-POWER-485-100 80 g QI-POWER-485-300 350 g
Terminal cable cross-section	0.05÷1.5 mm ² (30÷14 AWG)
Energy values storage	Flash, min 100k writings
Approvals and certifications	IEC 61010-1: 2010 - IEC 61010-2-030: 2010 - EN IEC 61326-1: 2021 EN IEC 61000-6-2: 2019 - EN IEC 61000-6-4: 2019 - CEI EN IEC 63000: 2021 CE UK CA C RA[®] US
Installation	DIN rail-ready with attachment clips provided

Order codes

50A version	QI-POWER-485-50
100A version	QI-POWER-485-100
300A version	QI-POWER-485-300
Attachment clips (50-100A)	90000009
Attachment clips (300A)	90000012



CONNECTION AND INSTALLATION

To meet different installation requirements, the unit can be mounted in four different ways (DIN rail or panel mounting, vertical or horizontal).

The system installation is as in the following image:

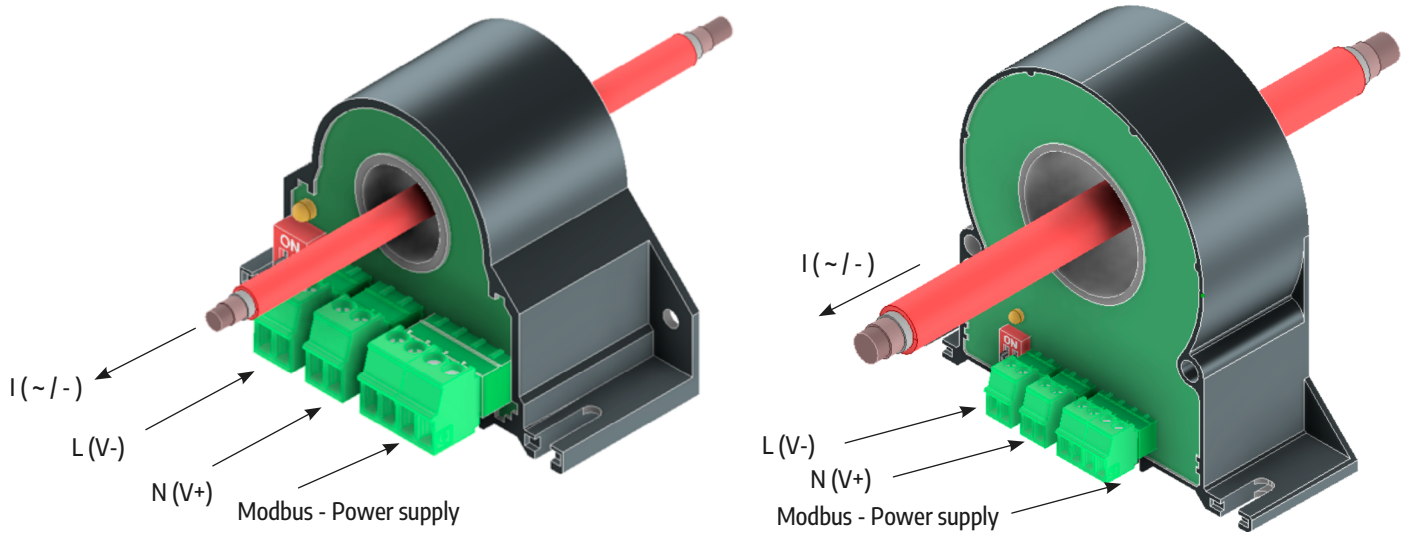

The conductor must be positioned as close to the product centre as possible to ensure correct current measurement.

PLEASE NOTE: If you wish to measure currents with intensities close to the lower measuring limit of the instrument, wind the conductor on the instrument so that it has a greater number of turns; in this case, change the transformation ratio in the dedicated register for correct current measurement.

WARNING: strong magnetic fields can alter the values measured by the instrument. Avoid installation near permanent magnets, electromagnets or ferrous masses that can significantly alter the magnetic field. In the event of anomalies, we recommend reorienting the instrument or moving it to a more suitable location.



AVAILABLE MEASUREMENT

The unit provides power readings in all 4 quadrants. The sign conventions used in the product are summarized in the following figure:

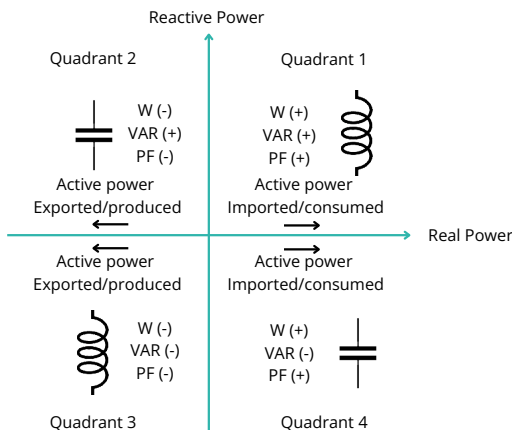

PRODUCT FEATURES

Using the configuration software or acting on the dedicated registers, the following functions can be configured:

Modbus

Address, baud rate, parity and response delay can be set.

Input/Output

- Measurement method [Reg. 40008]
- Enable energy flash storage [Reg. 40008]
- Frequency calculation channel [Reg. 40008]
- Ratio of transformations for voltage and current [Reg. 40009 - 40011]
- Measurement filtering [Reg. 40007]
- Current and power display threshold [Reg. 40013]

DEVICE CONFIGURATION

Baudrate setting via DIP switch

The baud rate can be set via DIP switches, before connecting and switching on the product. The possible combinations are shown below:

DIP 1	DIP 2	ADDRESS	BAUDRATE
0	X	RS485 settings from EEPROM	
1	0	1	9600
1	1	1	38400

Addresses other than 1 (default value) and baud rates other than those selected by the DIP switches can be configured using the **Q-WIZARD configuration software** or with the Modbus RTU functions below, by acting on the dedicated registers- see page 12.

PLEASE NOTE: to make active all changes via DIP-switch, it is necessary to remove and restore power to the device.



Functionality configuration

Through an RS485 serial device such as our Q-USB485, it is possible to connect to the product using the Modbus RTU input terminals.

Configuration of the module can be done with our **Q-WIZARD configuration software** or with any third-party Modbus master by acting on the registers in the map - see page 12.

Q-WIZARD

Using the **Q-WIZARD interface tool that can be downloaded from the link** it is possible to configure all device parameters by following the simple, self-explanatory steps.

In addition to the configuration of various parameters, inputs and outputs, the **Q-WIZARD** also allows real-time monitoring of device variables.

Third-party Modbus Master

Alternatively, the product can communicate directly with a third-party Modbus RTU Master using the communication settings according to the DIP switch configuration (when using microUSB the DIP switch settings are irrelevant).

The communication protocol supported is Modbus RTU Slave:

- Modbus RTU connections: A+ and B- according to Modbus RTU standards
- Supported Modbus RTU functions: 03 hexadecimal (read multiple registers, max 100), 06 hexadecimal (write single), 10 hexadecimal (write multiple registers)
- Modbus RTU address numbering is by convention '1 BASED' (standard), but the physical register is base 0; the logical address, e.g. 40010, corresponds to the physical address #9, as required by Modbus RTU standards

PLEASE NOTE: All setting changes of calibration and configuration parameters must be followed by the flash save command 0xC1C0 = Flash settings save command in register 40252; changes of device communication parameters in addition must also be followed by the command 0xC1A0 = Reboot command in register 40252.

In this case, all device configurations are performed by accessing the Modbus RTU register map available in the last chapter of this document using the functions:

- Read holding registers (function 03 hexadecimal)
- Write single holding register (function 06 hexadecimal)
- Write multiple registers (function 10 hexadecimal)



Function 03 Hexadecimal (Read Holding Registers)

This function is used to read the contents of a contiguous block of holding registers (words). The request frame specifies the source register address and the number of registers to read. A maximum of 120 registers (words) can be read with a single request, unless otherwise specified. The register data in the response message is packaged as two bytes per register (word), with the binary contents right-justified within each byte. For each register, the first byte contains the most significant bits (MSB) and the second byte contains the least significant bits (LSB).

Request Frame			
Description	Lenght	Value	Comments
Physical address	1 byte	1 to F7 HEX (1 to 247)	
Function code	1 byte	03 HEX	
Starting address	2 bytes	0000 to FFFF HEX	Bytes order: MSB, LSB
Number of registers (N word)	2 bytes	1 to 10 HEX (1 to 16)	Bytes order: MSB, LSB
CRC	2 bytes		

Response frame (right action)			
Description	Lenght	Value	Comments
Physical address	1 byte	1 to F7 HEX (1 to 247)	
Function code	1 byte	03 HEX	
Required Number of bytes	1 byte	N word * 2	
Register value	N*2 bytes		Bytes order: MSB, LSB
CRC	2 bytes		

Response frame (wrong action)			
Description	Lenght	Value	Comments
Physical address	1 byte	1 to F7 HEX (1 to 247)	Possible exception: 01: illegal function 02: illegal data address 03: Illegal data value 04: Slave device failure
Function code	1 byte	83 HEX	
Exception code	1 byte	01, 02, 03, 04 (see note)	
CRC	2 bytes		

Function 06 Hexadecimal (Write Single Holding Register)

This function is used to write a single holding register. The request frame specifies the address of the register (word) to be written and its contents. The correct response is an echo of the request, returned after the contents of the register have been written.

Request frame			
Description	Lenght	Value	Comments
Physical address	1 byte	1 to F7 HEX (1 to 247)	
Function code	1 byte	06 HEX	
Starting address	2 bytes	0000h to FFFF HEX	Bytes order: MSB, LSB
Register value	2 bytes	0000h to FFFF HEX	Bytes order: MSB, LSB
CRC	2 bytes		

Response frame (right action)			
Description	Lenght	Value	Comments
Physical address	1 byte	1 to F7 HEX (1 to 247)	
Function code	1 byte	06 HEX	
Starting address	2 bytes	0000h to FFFF HEX	Bytes order: MSB, LSB
Register value	2 bytes	0000h to FFFF HEX	Bytes order: MSB, LSB
CRC	2 bytes		

Response frame (wrong action)			
Description	Lenght	Value	Comments
Physical address	1 byte	1 to F7 HEX (1 to 247)	Possible exception: 01: illegal function 02: illegal data address 03: Illegal data value 04: Slave device failure
Function code	1 byte	86 HEX	
Exception code	1 byte	01, 02, 03, 04 (see note)	
CRC	2 bytes		



Function 10 Hexadecimal (Write Multiple Registers)

This function is used to write a block of contiguous registers (maximum of 2). The required values to be written are specified in the data field of the request. The data is packed as two bytes per register.

A correct response returns the function code, the starting address and the number of registers written.

Request frame			
Description	Lenght	Value	Comments
Physical address	1 byte	1 to F7 HEX (1 to 247)	
Function code	1 byte	10 HEX	
Starting address	2 bytes	0000 to FFFF HEX	Bytes order: MSB, LSB
Number of registers (N word)	2 bytes	0001 to 0078 HEX	Bytes order: MSB, LSB
Byte counting	1 byte	N word * 2	
Register value	N * 2 bytes	value	Bytes order: MSB, LSB
CRC	2 bytes		

Response frame (right action)			
Description	Lenght	Value	Comments
Physical address	1 byte	1 to F7 HEX (1 to 247)	
Function code	1 byte	10 HEX	
Starting address	2 bytes	0000 to FFFF HEX	Bytes order: MSB, LSB
Number of registers (N word)	2 bytes	0001 to 0078 HEX	Bytes order: MSB, LSB
CRC	2 bytes		

Response frame (wrong action)			
Description	Lenght	Value	Comments
Physical address	1 byte	1 to F7 HEX (1 to 247)	Possible exception: 01: illegal function 02: illegal data address 03: Illegal data value 04: Slave device failure
Function code	1 byte	90 HEX	
Exception code	1 byte	01, 02, 03, 04 (see note)	
CRC	2 bytes		

REGISTER MAP

 Default values are in **bold**.

Register Name	Description	Register Type	R/W	Default	Range	Address Modbus
Machine ID	7 = QI-POWER-485 18 = QI-POWER-485-300 48 = QI-POWER-485-100	UShort [16b]	R			40001
FW version	Firmware version	UShort [16b]	R	0		40002
Address	Modbus address	UShort [16b]	R/W	1		40003
Delay	Machine answer delay (in characters)	UShort [16b]	R/W	1	1...1000	40004
Baudrate	0=1200 1=2400 2=4800 3=9600 4=19200 5=38400 6=57600 7=115200	UShort [16b]	R/W	3	0...7	40005
Parity	0 = NONE 1 = ODD 2 = EVEN	UShort [16b]	R/W	0	0...2	40006
DC Filter	Number of tenths of second (1/10) for all RMS calculation in DC	UShort [16b]	R/W	10	1...65535	40007
Flag measurement	bit[0]: 0 = TRMS value (without sign) 1 = DC_measurement (with sign) bit[1]: 0 = Energy storing disabled 1= Energy storing enabled bit[2]: 0 = Frequency detect on Voltage channel disabled 1= Frequency detect on Current channel enabled	UShort [16b]	R/W	2		40008
TV_Ratio	Voltage transformer ratio	Float [32b-LSW]	R/W	1.0		40009
TA_Ratio	Current transformer ratio	Float [32b-LSW]	R/W	1.0		40011
Current and Power CUT OFF (*)	LSB: Current cutoff MSB: Power cutoff	UShort [16b]	R/W	See end of the table (*)		40013
# of ZX for VI measurement	Number of ZX for _AC Meas Number of line cycle Zero Crossings for AC measurement RMS.	UShort [16b]	R/W	50	1...65535	40014
Serial Number (year, Month)	Partial serial number (format: yy-MM)	UShort [16b]	R			40041
Serial Number (day, hour)	Partial serial number (format: dd-hh)	UShort [16b]	R			40050
Serial Number (min, sec)	Partial serial number (format: mm-ss)	UShort [16b]	R			40057
Status	bit[0]: flash settings error bit[1]: flash calibration error bit[2]: Voltage Over Range bit[3]: Voltage Under Range bit[4:5] don't care bit[6]: Zero crossing detecting bit[7:9] don't care bit[10]: Energy storing error bit[11]: Energy initialization error bit[12]: don't care bit[13]: Current Over Range bit[14]: Current Under Range bit[15]: don't care	UShort [16b]	R			40072
V RMS	Voltage RMS Measurement (V)	Float [32b-LSW]	R			40073
I RMS	Current RMS Measurement (mA)	Float [32b-LSW]	R			40075
P	Active Power Measurement (W)	Float [32b-LSW]	R			40077
Q	Reactive Power Measurement (VAR)	Float [32b-LSW]	R			40079
S	Apparent Power Measurement (VA)	Float [32b-LSW]	R			40081
Cosφ	Cosφ Measurement	Float [32b-LSW]	R			40083
Frequency	Frequency Measurement (Hz)	Float [32b-LSW]	R			40085
THD	THD Measurement	Float [32b-LSW]	R			40087
Energy	Total Energy Measurement (kWh)	Float [32b-LSW]	R			40089
Energy positive	Only positive Energy Measurement (kWh)	Float [32b-LSW]	R			40091
Energy negative	Only negative Energy Measurement (kWh)	Float [32b-LSW]	R			40093
V peak	Instantaneous Voltage Peak (V)	Float [32b-LSW]	R/W			40095
I peak	Instantaneous Current Peak (mA)	Float [32b-LSW]	R/W			40097
V MAX	Max RMS Voltage (V)	Float [32b-LSW]	R/W			40099
V min	Min RMS Voltage (V)	Float [32b-LSW]	R/W			40101
I MAX	Max RMS Current (mA)	Float [32b-LSW]	R/W			40103



Register Name	Description	Register Type	R/W	Default	Range	Address Modbus
I min	Min RMS Current (mA)	Float [32b-LSW]	R/W			40105
P MAX	Max RMS Power (W)	Float [32b-LSW]	R/W			40107
P min	Min RMS Power (W)	Float [32b-LSW]	R/W			40109
Q MAX	Max Reactive Power (VAR)	Float [32b-LSW]	R/W			40111
Q min	Min Reactive Power (VAR)	Float [32b-LSW]	R/W			40113
S MAX	Max Apparent Power (W)	Float [32b-LSW]	R/W			40115
S min	Min Apparent Power (W)	Float [32b-LSW]	R/W			40117
Cosφ MAX	Max Cosφ	Float [32b-LSW]	R/W			40119
Cosφ min	Min Cosφ	Float [32b-LSW]	R/W			40121
Frequency MAX	Max Frequency (Hz)	Float [32b-LSW]	R/W			40123
Frequency min	Min Frequency (Hz)	Float [32b-LSW]	R/W			40125
THD MAX	Max THD	Float [32b-LSW]	R/W			40127
THD min	Min THD	Float [32b-LSW]	R/W			40129
STATUS SW	bit[0]: flash settings error bit[1]: flash calibration error bit[2]: Voltage Over Range bit[3]: Voltage Under Range bit[4:5]: don't care bit bit[6]: Zero crossing detecting bit[7:9]: don't care bit[10]: Energy storing error bit[11]: Energy initialization error bit[12]: don't care bit[13]: Current Over Range bit[14]: Current Under Range bit[15]: don't care	UShort [16b]	R			40132
V RMS SW	Voltage RMS measurement (V) swapped	Float [32b-MSW]	R			40133
I RMS SW	Current RMS measurement (mA) swapped	Float [32b-MSW]	R			40135
P SW	Power measurement (W) swapped	Float [32b-MSW]	R			40137
Q SW	Reactive Power measurement Q (VAR) swapped	Float [32b-MSW]	R			40139
S SW	Apparent Power measurement S (VA) swapped	Float [32b-MSW]	R			40141
Cosφ SW	Cosφ measurement swapped	Float [32b-MSW]	R			40143
Frequency SW	Frequency measurement (Hz) swapped	Float [32b-MSW]	R			40145
THD SW	THD swapped	Float [32b-MSW]	R			40147
Energy SW	Total Energy measurement (kWh) swapped	Float [32b-MSW]	R			40149
Energy positive SW	Only positive Energy Measurement (kWh) swapped	Float [32b-MSW]	R			40151
Energy negative SW	Only negative Energy Measurement (kWh) swapped	Float [32b-MSW]	R			40153
V peak SW	Instantaneous Voltage Peak (V) swapped	Float [32b-MSW]	R/W			40155
I peak SW	Instantaneous Current Peak (mA) swapped	Float [32b-MSW]	R/W			40157
V MAX SW	Max RMS Voltage (V) swapped	Float [32b-MSW]	R/W			40159
V min SW	Min RMS Voltage (V) swapped	Float [32b-MSW]	R/W			40161
I MAX SW	Max RMS Current (mA) swapped	Float [32b-MSW]	R/W			40163
I min SW	Min RMS Current (mA) swapped	Float [32b-MSW]	R/W			40165
P MAX SW	Max RMS Power (W) swapped	Float [32b-MSW]	R/W			40167
P min SW	Min RMS Power (W) swapped	Float [32b-MSW]	R/W			40169
Q MAX SW	Max Reactive Power (VAR) swapped	Float [32b-MSW]	R/W			40171
Q min SW	Min Reactive Power (VAR) swapped	Float [32b-MSW]	R/W			40173
S MAX SW	Max Apparent Power (W) swapped	Float [32b-MSW]	R/W			40175
S min SW	Min Apparent Power (W) swapped	Float [32b-MSW]	R/W			40177
Cosφ MAX SW	Max Cosφ swapped	Float [32b-MSW]	R/W			40179
Cosφ min SW	Min Cosφ swapped	Float [32b-MSW]	R/W			40181
Frequency MAX SW	Max Frequency (Hz) swapped	Float [32b-MSW]	R/W			40183
Frequency min SW	Min Frequency (Hz) swapped	Float [32b-MSW]	R/W			40185
THD MAX SW	Max THD swapped	Float [32b-MSW]	R/W			40187
THD min SW	Min THD swapped	Float [32b-MSW]	R/W			40189
STATUS 100	bit[0]: flash settings error bit[1]: flash calibration error bit[2]: Voltage Over Range bit[3]: Voltage Under Range bit[4:5]: don't care bit[6]: Zero crossing detecting bit[7:9]: don't care bit[10]: Energy storing error bit[11]: Energy initialization error bit[12]: don't care bit[13]: Current Over Range bit[14]: Current Under Range bit[15]: don't care	UShort [16b]	R			40192



Register Name	Description	Register Type	R/W	Default	Range	Address Modbus
V RMS 100	Voltage RMS measurement (V/100) in hundredths	Long [32b-LSW]	R			40193
I RMS 100	Current RMS measurement (mA/100) in hundredths	Long [32b-LSW]	R			40195
P 100	Power measurement (W/100) in hundredths	Long [32b-LSW]	R			40197
Q 100	Reactive Power measurement Q (VAR/100) in hundredths	Long [32b-LSW]	R			40199
S 100	Apparent Power measurement S (VA/100) in hundredths	Long [32b-LSW]	R			40201
Cosφ 100	Cosφ measurement in hundredths	Long [32b-LSW]	R			40203
Frequency 100	Frequency measurement (Hz/100) in hundredths	Long [32b-LSW]	R			40205
THD 100	THD in hundredths	Long [32b-LSW]	R			40207
Energy 100	Total Energy measurement (KWh) swapped Energy positive	Long [32b-MSW]	R			40209
Energy Positive 100	Only positive Energy Measurement (kWh/100) in hundredths	Long [32b-LSW]	R			40211
Energy negative 100	Only negative Energy Measurement (kWh/100) in hundredths	Long [32b-LSW]	R			40213
V peak 100	Instantaneous Voltage Peak (V/100) in hundredths	Long [32b-LSW]	R/W			40215
I peak 100	Instantaneous Current Peak (mA/100) in hundredths	Long [32b-LSW]	R/W			40217
V MAX 100	Max RMS Voltage (V/100) in hundredths	Long [32b-LSW]	R/W			40219
V min 100	Min RMS Voltage (V/100) in hundredths	Long [32b-LSW]	R/W			40221
I MAX 100	Max RMS Current (mA/100) in hundredths	Long [32b-LSW]	R/W			40223
I min 100	Min RMS Current (mA/100) in hundredths	Long [32b-LSW]	R/W			40225
P MAX 100	Max RMS Power (W/100) in hundredths	Long [32b-LSW]	R/W			40227
P min 100	Min RMS Power (W/100) in hundredths	Long [32b-LSW]	R/W			40229
Q MAX 100	Max Reactive Power (VAR/100) in hundredths	Long [32b-LSW]	R/W			40231
Q min 100	Min Reactive Power (VAR/100) in hundredths	Long [32b-LSW]	R/W			40233
S MAX 100	Max Apparent Power (W/100) in hundredths	Long [32b-LSW]	R/W			40235
S min 100	Min Apparent Power (W/100) in hundredths	Long [32b-LSW]	R/W			40237
Cosφ MAX 100	Max Cosφ swapped in hundredths	Long [32b-MSW]	R/W			40239
Cosφ min 100	Min Cosφ swapped in hundredths	Long [32b-MSW]	R/W			40241
Frequency MAX 100	Max Frequency (Hz/100) in hundredths	Long [32b-LSW]	R/W			40243
Frequency min 100	Min Frequency (Hz/100) in hundredths	Long [32b-LSW]	R/W			40245
THD MAX 100	Max THD swapped in hundredths	Long [32b-MSW]	R/W			40247
THD min 100	Min THD swapped in hundredths	Long [32b-MSW]	R/W			40249
Command	0xC1C0 = Flash settings save command 0xC1A0 = Reboot command 0xBABA = Load Energy command (energy to load must be written in Command_aux) 0xBABB = Load Positive Energy command (positive energy to load must be written in Command_aux) 0xBABC = Load Negative Energy command (negative energy to load must be written in Command_aux)	UShort [16b]	R/W	0		40252
Command aux	Auxiliary Register for Energy Command (see command register)	Float [32b-LSW]	R/W	0		40253

(*) The LSB and MSB values written in register 40013 are the cutoff values (minimum accepted value) for currents and powers (default values in brackets).
For each model, the cutoff values are:

	FW rev. < 37	FW rev. ≥ 37
QI-POWER-485	1x mA the value written into the register (default 0xFA=250mA) 1x W the value written into the register (default 0x01=1W)	4x mA the value written into the register (default 0x7D=500mA) 4x W the value written into the register (default 0x01=4W)
QI-POWER-485-300, QI-POWER-485-100	10x mA the value written into the register (default 0x96=1500mA) 10x W the value written into the register (default 0x01=10W)	40x mA the value written into the register (default 0x4B=3000mA) 40x W the value written into the register (default 0x01=40W)

LEGEND:

Short [16b] = Signed Short (16 bit)
UShort [16b] = Unsigned Short (16 bit)

Long [32b-MSW] = Signed Long (32 bit - MSW First Register)
Long [32b-LWS] = Signed Long (32 bit - LSW First Register)
ULong [32b-LSW] = Unsigned Long (32 bit - LSW First Register)
ULong [32b] = Unsigned Long (32 bit)

Float [32b-MSW] = Float (32 bit - MSW First Register)
Float [32b-LSW] = Float (32 bit - LSW First Register)

UInt [16b] = Unsigned Integer (16 bit)
UInt [32b-MSW] = Unsigned Integer (32 bit - MSW First Register)
Int [64b-LSW] = Signed Long Long (64 bit - LSW First Register)